



ALPINE TECHNICAL MANUAL



CONTENT

1/	EDITORIAL	3
2/	HISTORY	4-5
3/	SKI	
	TECHNOLOGIES +	
	CONSTRUCTION	6
	BASE, FINISHES	7-8
	LENGTH RECOMMENDATION	
	ACC. TO TARGET GROUP	9
4/	SKI CARE AND	
	PREPARATION	10
5/	BINDINGS	11-101
6/	BOOTS	102-105
7/	APPENDIX BINDINGS	106-123

TECHNICAL HANDBOOK

THE FISCHER TECHNICAL HANDBOOK

As a salesperson you are extremely important to the future of Alpine skiing. You convey your knowledge and enjoyment of the sport directly to the customer. Only if you are able to provide proper advice will the customer be able to experience enthusiasm for the sport in the way you do.

At FISCHER we value your passion for skiing and want to help you convey this enthusiasm to your customers with the best products and the latest information. This technical handbook is intended as one of the tools to assist you. It should be a real help to everybody involved in skiing. We have input all our experience to support you with clear, useful information, and not just on FISCHER products. This handbook will extend your knowledge of Alpine skiing and make it easier for you to sell the FISCHER brand.

There are a number of information sources open to your customers in addition to this handbook (fischersports.com).

We are certain that this technical handbook will support you in your daily work. We would be pleased to hear from you with any suggestions for keeping the information up-to-date.

We wish you a successful winter!

Your FISCHER Alpine Team.

Ried, May 2016



THE HISTORY OF FISCHER

FISCHER IS AN OUTSTANDING INNOVATOR IN THE ALPINE SKI SECTOR.

From sledges to Skifahrwerk™ (the latest ski suspension technology). FISCHER has been at home in the snow for more than 80 years. Based in Ried im Innkreis, Upper Austria, the company offers a complete range of Alpine and cross country ski equipment. Skis, boots, bindings, tennis rackets and hockey sticks are sold worldwide.



The company was founded in 1924 by Josef Fischer senior, who in the beginning mainly produced rack wagons and toboggans, plus skis made to order. By 1934 the factory employed 85 staff and was making 40,000 pairs of skis.



In 1958 FISCHER evolved from being merely a ski manufacturer into a brand. Rudolf Ferch designed the corporate logo consisting of three equal triangles. At the time nobody could have guessed that it was to become one of the most famous symbols in the sport industry.

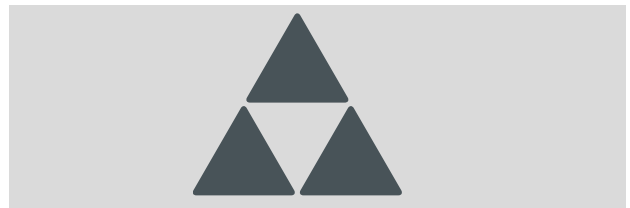

In 1964 all signs point to success: with Austrian Egon Zimmermann's victory in the Olympic Downhill in Innsbruck FISCHER wins the first Gold medal in its history. More than 250,000 pairs of skis are sold in this season. The winning "Alu-Steel" ski was the first metal ski to make a breakthrough with 40% of the market share worldwide.



Franz Klammer heralds a golden era on the FISCHER C4 starting in 1973. The national hero wins the Olympics in Innsbruck in 1976, dominates Alpine racing for years and goes down in the history books as the most successful downhill skier of all time.



In 2001 with the help of "Frequency Tuning" a start is made on improving the oscillation properties of skis. The result - much smoother running skis - conquer the market the very next season. In 2003 FISCHER enters new ground by launching Soma-Tec, the first ski boot to adapt to the anatomy of the human foot. The feet can now maintain their natural V-Position, even while skiing. Comfort that has a very positive influence on performance.



The Hole Ski, already used by Fischer in the speed disciplines between 1975 and 1985, has been back in the World Cup since 07/08.



There was a milestone in the development of ski boots in 2011. Fischer launched VACUUM FIT at ISPO, causing a sensation with a development that has truly revolutionised the boot market. The first ski boot that has a 100% fit!



14/15: Fischer develops the first ski tour boot which is fully adaptable. For the first time VACUUM is available also for a touring ski boot. More freedom of movement, better power transfer and a perfect fit - Fischer Transalp VACUUM: a new milestone.



15/16: Improved efficiency and less energy consumption due to optimized glide characteristics: Fischer's exclusive new PROFOIL is the easy-to-use and lightweight solution for back-country adventurers, randonnée skiers, and winter alpinists. This revolutionary adhesive full-length ski base attachment powered by Fischer's Crown Technology allows you to lengthen your uphill stride and provides permanent grip in all conditions.



16/17: THE CURV: Absolute curve performance in an exclusive form developed by the three skiing legends Hans Knauss, Mike von Grüningen and Kristian Ghedina. Extremely close to the pro equipment used in World Cup skiing and suitable for the piste nevertheless. With THE CURV you can master extreme performance thanks to a high-quality technology package.



CONSTRUCTIONS

SKI TECHNOLOGY

CORES

AIR POWER

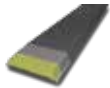

Ski core with less density. The reduced ski weight means easier handling and less energetic skiing.

SANDWICH CONSTRUCTION



Laminated construction with a wooden core and sidewalls to support the edges for highest stability, strength and durability.

SANDWICH SIDEWALL CONSTRUCTION

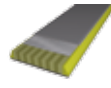

Wood core combined with ABS sidewalls in a classic Sandwich Construction for balanced flex and perfect rebound.

SIDEWALL CONSTRUCTION

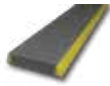

Sidewall Construction to support the edges for highest stability, strength and durability.

TECHNOLOGIES

KICKDOWN

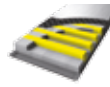

Automatic ski adaption to different conditions and speeds. The higher the forces and the speed, the stiffer and sporty the ski.

AIR CARBON TI

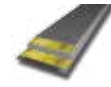

Wood Core with double Titanal shell, reinforced with Air Carbon. Perfect edge grip and extremely smooth running as a result.

AIR CARBON

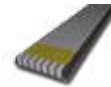

Ultra lightweight and extremely strong high-tech material from the aerospace industry. Improves handling and performance.

CARBON TECH

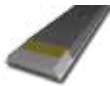

Special network of carbon fibres with exceptional torsion properties and a balanced stiffness pattern at the same time.

FIBER TECH

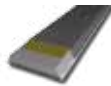

Special glass fibre network with harmonious bending properties. The ski stands out through excellent turning action.

CARBON-STRINGERS

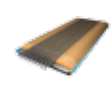

Special Carbon Stringers ensure that weight is kept sensationally low with balanced flex and an optimised weight-torsion ratio.

AEROSHAPE

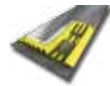

Special lightweight design for extreme torsion stability.

AIR TEC

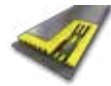

On the one hand, the milled structure makes the core 25 % lighter and, on the other hand maintains the outstanding ski performance.

AIR TEC TI

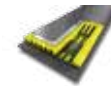

Air Tec + Titanal give you optimum performance and minimum weight.

HOLE SKI TECHNOLOGY



Lower mass inertia moment thanks to less weight in the ski's tip and tail for improved oscillation behaviour, perfectly smooth running and better turning and control.

DUAL RADIUS SYSTEM



Different radiuses at the ski tip and ski tail give you faster turn initiation and outstanding performance in both long and short turns.

ROCKER



The shorter contact length of the ski ensures that turn initiation is easier and requires less effort. Five different types: All Mountain ROCKER, Freeski ROCKER, Tour ROCKER, On Piste ROCKER, Hybrid ROCKER.

RAZORSHAPE

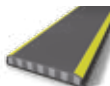

Levelled sidewalls give the ski its special, razor-sharp shape. First and foremost, of course, this saves weight. On the other hand, however, this new, distinctive ski shape offers sporty on-piste skiers additional speed and action as it has a smaller contact surface in the snow.

TUNED CARBON METAL



Special titanium top-layer adapted to the target group.

CARBON NOSE TIP AND TAIL



Ultra slim shovel with carbon inlay improves maneuverability at high stability.

CONCAVE SIDEWALL



New manufacturing standard for easier edge tuning.

DIAGOTEX™



Innovative carbon grid for top torsional stability. For maximum power and stability in turns.

TRIPLE RADIUS



The Triple Radius shape enables better control and power transfer throughout the entire turn.

CHARACTER SIZE



The collection consists of various ski lengths – the perfect ski for every skiing style. For perfect short, medium or long turns.

FREE MILLED TITANIUM



Titanal visible on top surface. New, extremely robust manufacturing standard.

TUNED CARBON



Special carbon layer adapted to the target group.

PLATES

CURV BOOSTER



The two-section plate makes cornering extremely quick and ensures optimum power transfer.

SLR 2



New, two-part system solution with minimum weight. For perfect power transfer.

RACETRACK



Optimised flex with free flex action, best possible piste contact, direct power transfer and straight boot position.

RACE PLATE JR.



New Junior Race Plate taken from the World Cup for junior competitions.

POWERTRACK



Best performance with optimized Flex, low weight and a low stand position. Features: Tool free mounting and adjustment.

POWERRAIL



Further development of Railflex – but wider and lower for improved power transfer. Special features: tool-free adjustment possible, suitable for rental.

WOMEN

WOMENTRACK



Railflex integration system for the Women range. Narrower and lighter than the unisex line. Sole only up to 330 mm (not 360 mm).

WOMEN BMP



Forward binding mounting point to make turning easier for energy-saving skiing.

POPLAR WOOD CORE + AIR CHANNEL



Air channels save considerable weight.

EDGE

WORLD CUP TUNING

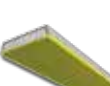

Edges and base are given an extremely precise World Cup level finish on the most modern grinding line in the world.

WORLD CUP BASE



Original World Cup base with inserts to protect the ski from burning out through heat build-up.

BASE, FINISHES

The base provides contact to the snow. The base gives the ski optimum gliding capabilities. Skiing "Schuss" or carving, a base that has been looked after and properly waxed reduces friction to increase enjoyment and make skiing easier.

TYPES OF BASE

SINTERED (GRAPHITE)

Sintering involves slowly melting polyethylene powder in a heated steel mould to form discs under high pressure. The ski bases are then peeled in strips from the sintered disc using a very sharp knife. Sintered bases have exceptional waxing properties and a very long service life.

TRANSPARENT

Sintered, transparent bases have an extremely pure material composition (no soot particles) and are therefore ideal for printing. The mechanical properties are the same as for a sintered graphite base.

EXTRUDED

Polyethylene granulate is melted in a heated extruder, rolled into mats and then cut into strips. The finished bases are then rolled up. Extruded base material is very hard-wearing, but does not possess as good waxing properties as sintered bases.

CUT BASES

A special cutting process is used on extruded or sintered bases to insert different colours of base material into the main base, achieving an eye-catching visual effect without compromising on the gliding properties of the ski base.

FINISH/STRUCTURE

To improve the gliding properties of the ski even further, the base is given different finishes, structures or embossed patterns to match different snow types and temperatures.

GRINDING

Various base structures are achieved using different grinding methods where the embossing process is not possible. Grinding with synthetic or natural diamonds gives the base the optimum structure. As a rule, deep and rough structures are ideal for damp and warm conditions, whereas for cold and dry conditions the ski base is given a finer structure for a flat running surface with perfect gliding properties.

EMBOSSING

The base of the ski is heated up and embossed under pressure using a roller with a defined structure. This process guarantees consistent base structures, especially on extruded bases.

BENEFIT TO THE CUSTOMER

Using various bases and structures fulfils the requirements of the customers and their respective target groups.

GRAPHITE BASES/
RACE SKI STRUCTURE
For optimum gliding.

TRANSPARENT BASES
For base designs.

CUT BASES
For design inserts in graphite bases, combines top gliding properties and design.

BASE, FINISHES

EDGES

The edges on our Alpine skis are made of special spring steels that can be easily hardened and ensure best elasticity and toughness. As a result this material is highly resistant to wear and provides a long service life.

STANDARD EDGES

Finish: base angles - 0.6 to 1.2 degrees, side edge angle - 3 to 4 degrees. The hanging base angle makes the ski easier to turn and easier to control.

RENTAL EDGES

Due to the wider, reinforced edge these edges can be reground up to 30 times on a ski servicing line. The service life of the skis is increased and the ski can be rented out more often than comparable rental skis. Wider edges for frequent ski servicing.



SLOPESTYLE

Park and Pipe skis require special edge specifications due to the high stresses that occur during jumps and slides over rails etc. This special edge is extremely wear-resistant and robust thanks to an edge geometry that is larger than on conventional steel edges. Extra robust and rounded for ideal sliding on rails and for jumping.



RACING BASE FINISH S15

The very latest finish from the World Cup for outstanding gliding.



BENEFIT TO THE CUSTOMER

Using a variety of edges and edge angles caters perfectly for all the requirements of the customers and their respective target groups.

RENTAL EDGES: Broader, reinforced edges that can be ground up to 30 times.

SLOPESTYLE EDGES: Particularly robust and hard-wearing edges for landings on rails.

RACING EDGES: Optimally prepared edges for perfect grip.

FINISH/STRUCTURE STANDARD "T"

Edge angle on base side 0,3°, optical base structure hangs left or right 30-60°, surface finish roughness 3-5 µm, flatness 0.10 mm and stone pattern more widely-spaced.



FINISH/STRUCTURE STANDARD "JR."

Edge angle on base side 0,6-1°, optical base structure hangs left 50-60°, surface finish roughness 3-4 µm, flatness 0.20 mm and stone pattern closely-spaced.



YELLOW BASE

New, yellow, with lateral black inserts to avoid the burning out of the base.

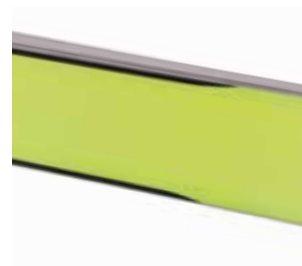

RECOMMENDED LENGTHS ACCORDING TO TARGET GROUPS

This chart shows the maximum and minimum ski length in relation to the skier's height. We recommend the lengths in the yellow area depending on the requirements and

skills of the various target groups. If the product features **ROCKER** technology we recommend adding 5 cm to the recommended ski length.

MEN

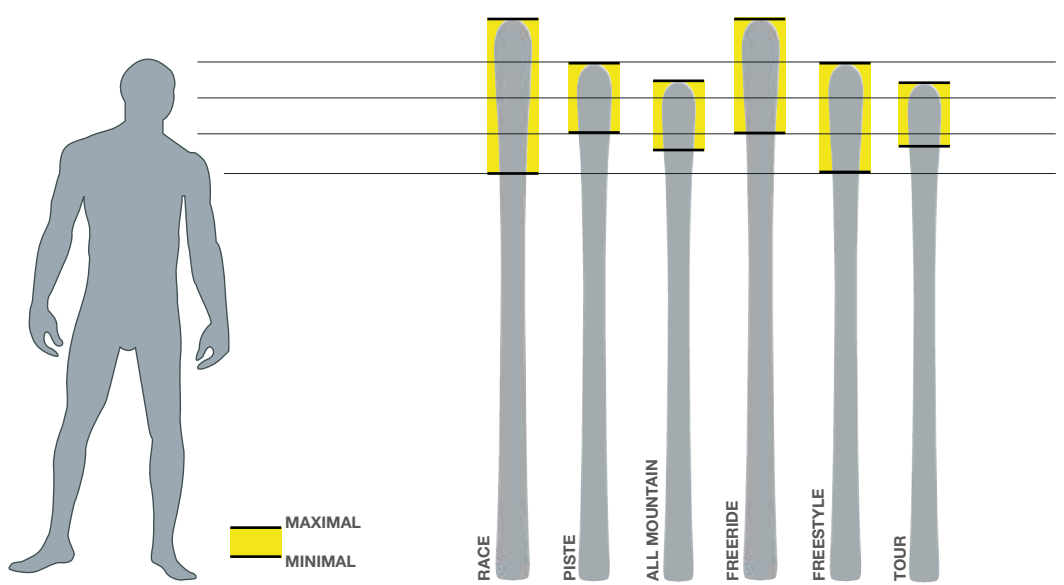

WOMEN

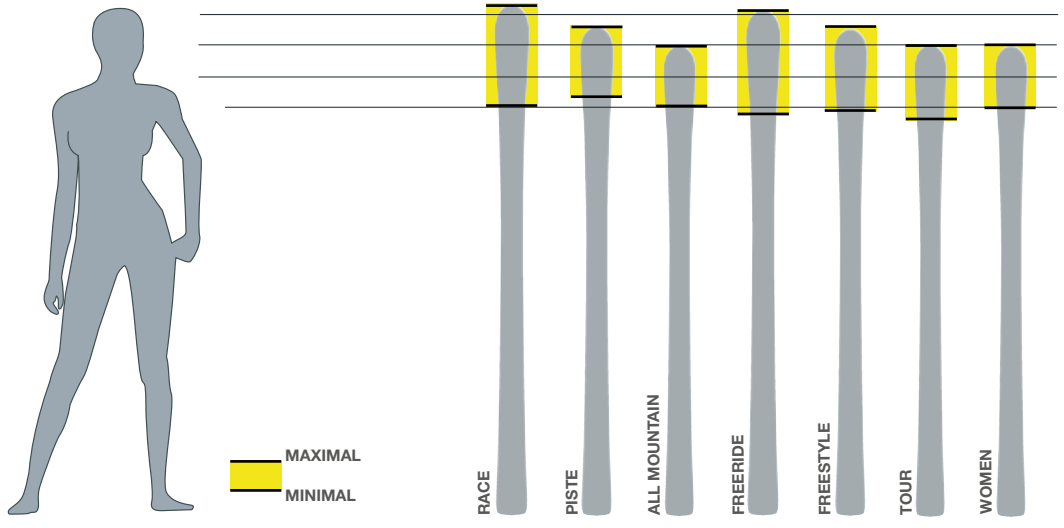

JUNIOR

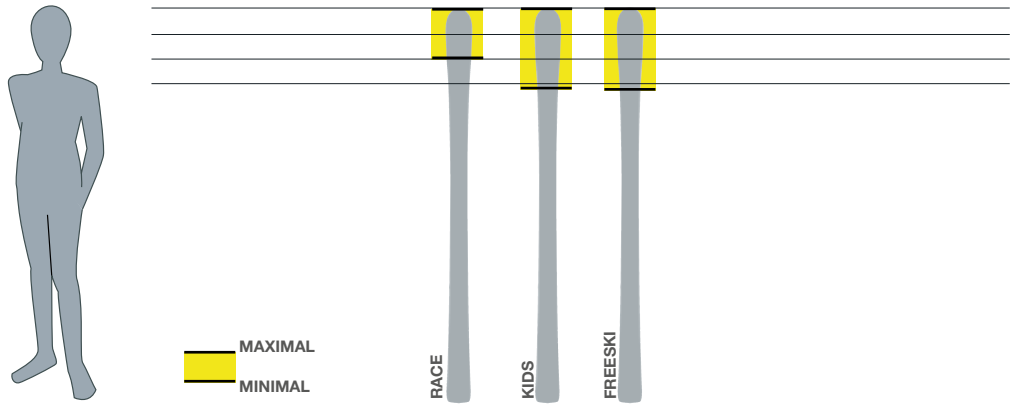

CARE AND PREPARATION

PREPARATION - FILING EDGES

1. Remove the sidewall: The sidewall ridge is filed away so the edge can be sharpened more easily.



2. Filing the edges: The idea edge angle is 87 – 88° for perfect edge grip. Filing jigs can be obtained in specialist sports shops. Step 1 rough file, Step 2 fine finish using diamond file.



PREPARATION - WAXING

1. Clean the base: Dirt, dust and wax remnants can be removed using a cleaning solvent obtainable from specialist sports shops.

IMPORTANT: Before moving on to the next steps, air the ski well (leave it outside for at least 15 minutes). An alternative is hot waxing (iron on wax and immediately scrape off soft gliding wax).



2. Apply wax: The wax is melted using a waxing iron and dripped onto the base of the ski.

NOTE: The waxing iron is at the correct temperature when the wax melts uniformly without forming smoke.



3. Iron on wax: The temperature needs to be set to between 110 and 130 °C. The waxing iron is drawn across the base at a constant speed in the skiing direction.

NOTE: Do not iron backwards and forwards or concentrate on one spot because there is a risk of the base overheating.



4. Allow the ski to cool for 5 to 10 minutes before removing excess wax. Use a sharp perspex edge to remove the wax by applying a constant, light pressure in the direction of skiing.



5. Brush the running surface with a nylon and/or combined brush in the direction of skiing. For the best possible gliding results, the structure of the base must be brushed thoroughly to remove any residual wax.



TOUR

1. BINDING TYPES AND COMPONENTS

1.1 BINDUNG TYPES

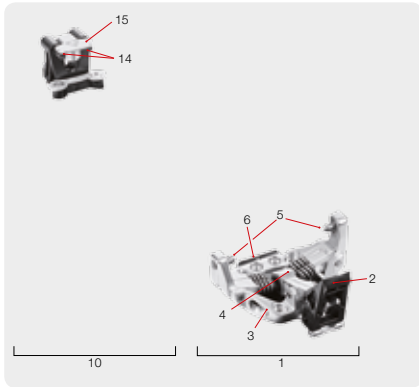

TOUR RACE LITE (T70016)

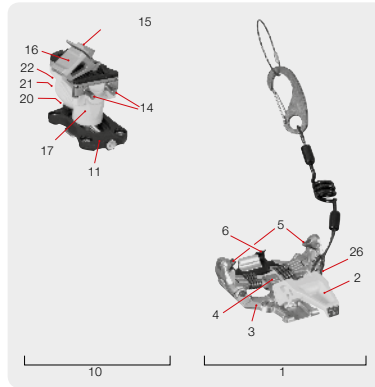

TOUR SPEED LITE (T70115)

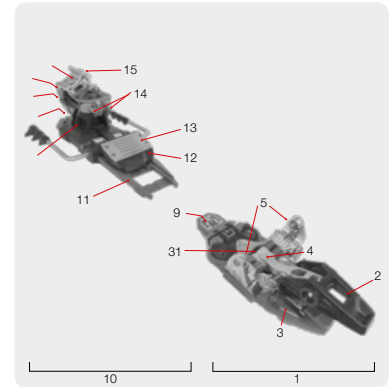

TOUR CLASSIC 90/105/120 (T70215, T70315, T70415)

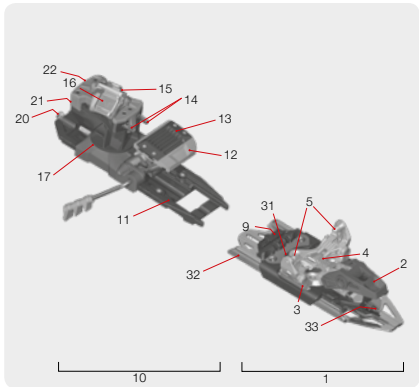

TOUR CLASSIC DEMO 90/105 (T70515/T70615)

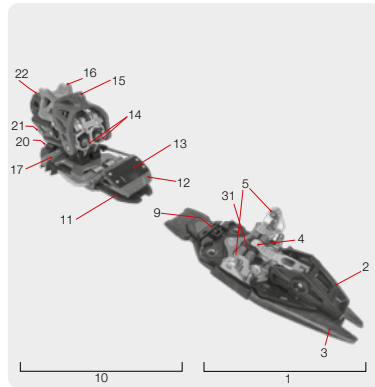

TOUR FREERIDE 14 105/120 (T70715/T70815)

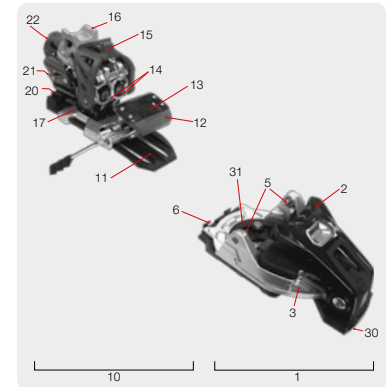

TOUR FREERIDE 16 120 (T71015)

- | | |
|--|--|
| <ol style="list-style-type: none"> 1. Toe 2. Locking lever 3. Base plate 4. Tensioning fork 5. Bolt 6. Crampon plate 7. Shock absorber 8. Carbon plate 9. Spacer 10. Heel piece 11. Base 12. Pedal 13. Gliding AFD 14. Release bolt 15. Climbing aid 1 16. Climbing aid 2 17. Housing | <ol style="list-style-type: none"> 18. Damping element 19. Brake base plate 20. Length adjustment screw 21. Adjustment screw for lateral release 22. Adjustment screw for forward release 23. Front brace 24. Heel brace 25. Crampon 26. Loop for ski leash 27. Fork support LTR 28. Base support plate Rental 29. Power Insert 30. Safety catch 31. Turning plate 32. Sliding plate 33. Lever |
|--|--|

1.2 COMPONENTS

Drilling gauge, Item No. T76115 (Template Classic, Freeride)
 Drilling gauge, Item No.: T76016 (Template Race Lite)



Drilling gauge, Item No.: T76015 (Template Speed Lite, Race)

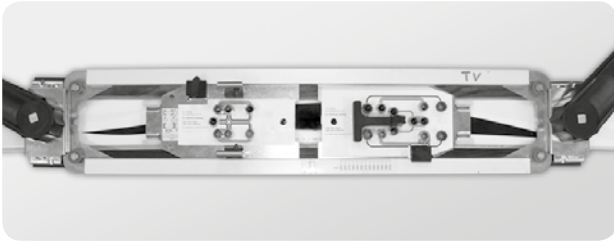

5.5 mm feeler gauge, included in binding pack (Tour Speed Lite)



4 mm feeler gauge, included in packaging of binding (Tour Race only)



Rental tool 8 Allen key,
 T75715 Tour Classic Adjustment Tool



Step drill 2,5mm, T75815 Driller insert Tour Freeride



Ski boot braces and crampons (T75015, T75115, T75215, T75315, T75415)

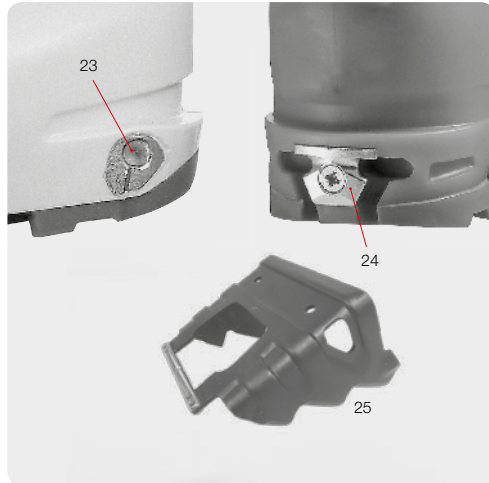

Power insert



2. GENERAL GUIDELINES / NOTES

As an authorized retailer you are required to check all parts of the equipment according to DIN/ISO 11088 before installation or adjustment of skis, ski bindings, and ski boots. If necessary, you must adjust or replace components suitable for the skier.

Guidelines for ski binding inspection

All new Fischer ski bindings comply with the current technical requirements. Tour Race bindings are specially designed for racing however and users should be aware of the increased risks involved using these bindings. These bindings do not conform to the DIN / ISO 11088 standard. The Tour Race bindings do not possess a release function.

Before installation and adjustment of a Fischer ski binding, perform a visual inspection. This is in particularly important for used ski bindings.

- Check if the release setting has been adjusted to the respective skier.
- Damage of the surfaces: Check the surfaces that contact the ski boot directly for wear and tear or any evident damage. Repair any worn or damage parts or replace these with new ones.
- Ski brake: Check if it is broken or bent and make sure that it functions properly. Check if any screws are missing.
- Scales: Check readability and adjustability of these.
- All surfaces of the ski binding should be clean. Check for dirt, corrosion and damage caused by rust. If the ski binding is dirty, clean it with a dry or moist cloth. Do not use any solvents for cleaning the ski binding, nor silicone or other lubrications on the holding parts (bolts, release bolts). Replace any damaged parts.

Guidelines for ski inspection

Most skis have a reinforced area for mounting the ski binding (E DIN ISO 8364). However, as skis may vary in material, design and dimensions, it is important to follow the instructions of the ski manufacturer for correct ski binding installation. Follow the manufacturer's recommendations regarding drill diameters, gluing materials or thread cutting.

Before installation and adjustment of a Fischer ski binding, perform a visual inspection. This is in particularly important for used ski bindings.

If inserts or braces show heavy wear, check if these can be

clamped securely in the binding. Fischer only guarantees perfect boot-binding function when used with DYNAFIT CERTIFIED INSERTS. For inserts from other manufacturers, Fischer cannot guarantee correct functioning and quality. Certain models of touring boots, particularly lightweight boots with a shortened heel fixation point, should be not used with the Tour Freeride binding.

In particular observe the following notes:



Important steps that directly affect function and safety.



Important steps that must be especially observed during assembly and setting.

3. DRILLING

3.1 GENERAL NOTES DRILLING JIGS

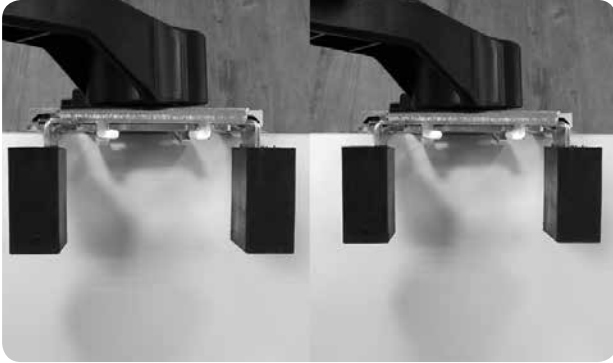

Insert the 4 rubber jaw clamps of the drilling jig in the required position, taking care to position them in the same way on each side of the jig.

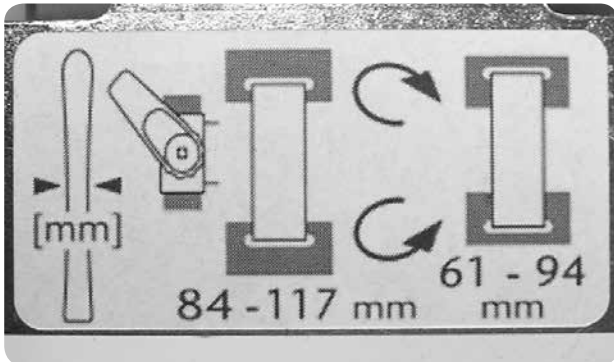

Clamping width depends on ski width.
 Tour Freeride, Tour Classic (85-145mm)
 Tour Race, Tour Speed Lite (61-117mm)

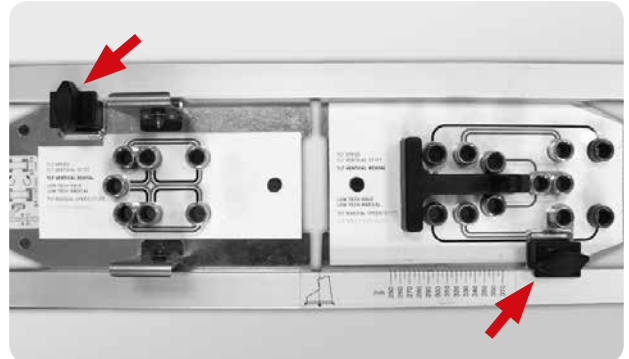

For setting the sole length, open the 2 fastening elements on the drilling gauge.
 Tighten these again once the adjustment has been completed.

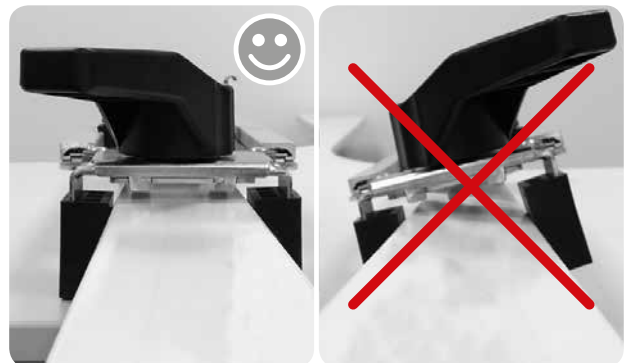
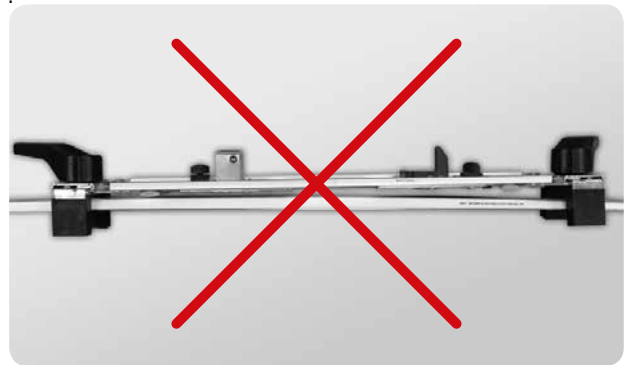

The drilling gauge must rest flat and straight on the ski.

3.2. ADJUSTMENT OF SOLE LENGTH

Version 1:

Adjustment of sole length without ski boot.

- Open the 2 fastening elements on the drilling gauge.
- Adjust sole length for the desired sole length range:

i Sole length adjustment 290 for 267,5-312,5
 Sole length adjustment 310 for 287,5-332,5
 Sole length adjustment 330 for 307,5-352,5
 (valid for Tour Classig bindings only)

- Retighten the 2 fastening elements.

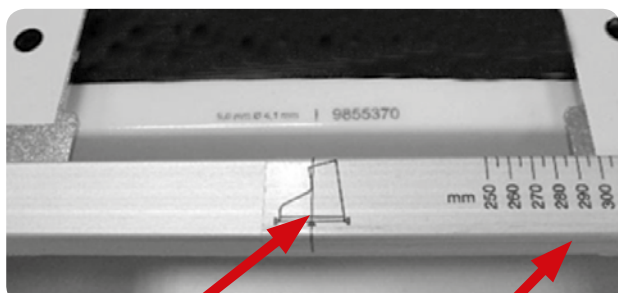

Ski midsole mark

e.g. boot sole length 290

Version 2:

Adjusting sole length using the ski boot.

- Open the 2 fastening elements on the drilling gauge.
- Clamp ski boot with the front brace into the bolt on the drilling gauge.



- Move rear drilling plate on the drilling gauge to the boot sole until the boot stop rests against the rear end of the sole.
- Tighten fastening elements
- Place drilling gauge flat on the ski and clamp it so that the midsole mark on the ski and the mark on the gauge are aligned.



3.3 Drilling the ski

- Unless anything deviating from this has been specified by the manufacturer, use step drill $\text{Ø } 4.1 \times 9$.
- Drill all holes for the required ski binding through the drill bushings of the drilling gauge up to the stop of the step drill.



- Do not use blunt drill bits. Do not drill in an inclined position. Do not cant.
- After drilling, remove the drilling gauge from the ski.

Remove drilling dust and chips from the drill holes and from the surface of the ski.



4. MOUNTING

4.1 TOUR RACE



In order to ensure the correct mounting length for the TOUR RACE binding we expressly recommend fixing the sole length on the mounting gauge with boot (version 2, chapter 3.2)! It is not possible to adjust the sole length afterwards on the binding!

Align the binding parts exactly over the drill holes on the ski and, beginning with the heel piece, tighten the screws by hand.

Do not tighten the screws at the front of the toe piece until the boot is in place, then remove the boot and also tighten the rear screws of the toe piece by hand.

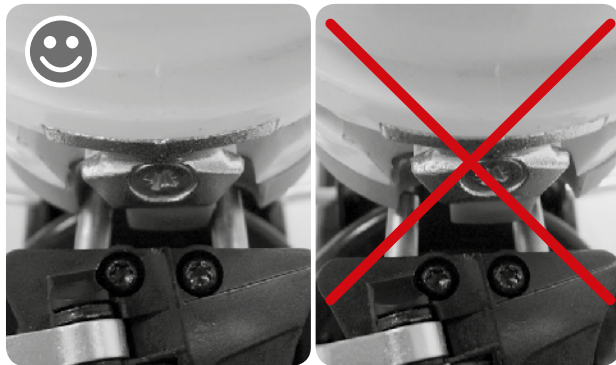

Repair overtightened screws with commercially available repair kits as specified by the manufacturer.

Use the 4 mm feeler gauge for checking the distance between the ski boot and the heel piece (included in the binding delivery).



Crampon bracket Tour Race

For mounting crampons

- Insert crampon bracket into the toe up to the stop and fasten with 2 screws to the base plate. Use 2.5 mm Allen key.

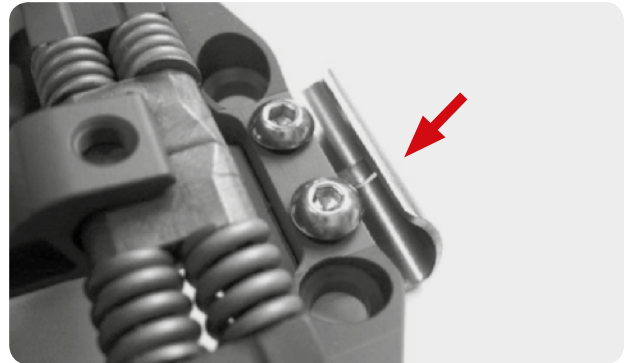

4.2 TOUR SPEED LITE

Mounting binding on ski

- Place the binding on the ski so that the binding screws are aligned with the holes in the ski.
- Only use adhesive for the screws for sealing the hole if this has been specified by the ski manufacturer.
- Screw on toe piece, but do not tighten the screws yet

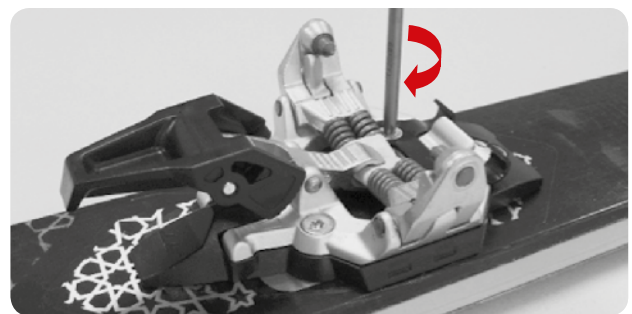

Place the ski boot in the binding while making sure that the boot is parallel to the ski binding.

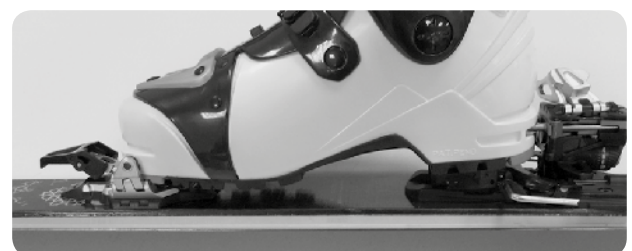

Tighten the front screws of the toe by hand



Remove the ski boot from the binding and tighten the rear screws of the toe piece by hand.



Do not overtighten the screws.

If screws have been overtightened, repair them using commercially available repair kits according to the specifications of the manufacturer.

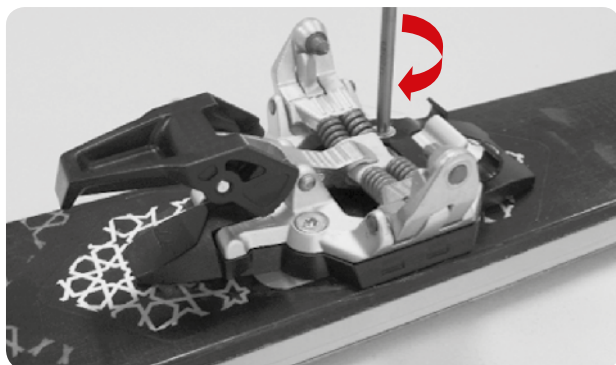

Check: Toe and heel piece must be screwed in one line on the ski.



Attention! The sliding plate under the heel has sharp edges. Danger of injury at installation on the ski. Do not overtighten the screws.

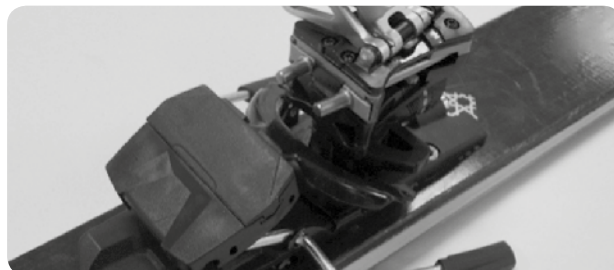

Fasten screws for the heel piece by hand.

Apply the sticker describing the locking functions in front of the toe piece.

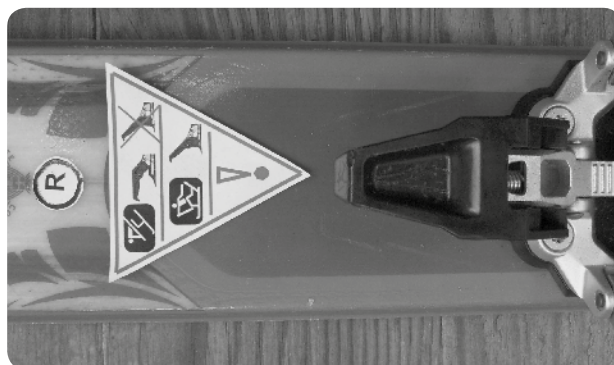

Sole length adjustment

- Place the ski boot in the binding.
- Use included feeler gauge to adjust the length.
- Place feeler gauge between the heel brace and the heel housing.
- Turn length adjustment screw with crosshead screwdriver PZ3, for Rental binding with Rental tool, at the heel piece until the correct distance is set.

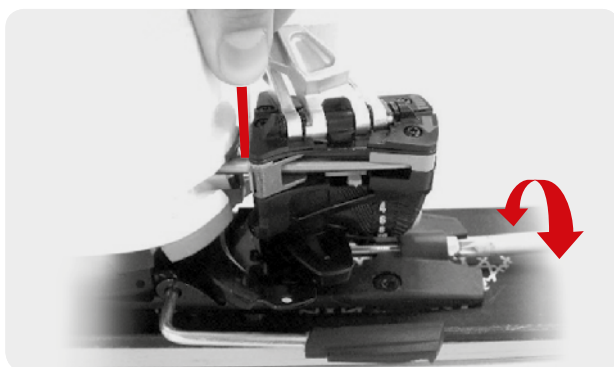

Caution: Do not overtighten the screw in order to reach the correct distance position. Mind the marks on the base!

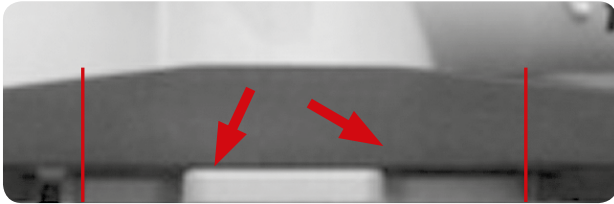

Marks Tour Speed Lite

The feeler gauge may not have any pressure marks and it must be possible to move without play between the ski boot and the heel housing.

Caution: For bindings with forward adjustment, the 3 indicators on the feeler gauge should form a straight line, as shown below. Repeat the setting procedure: step out of the binding with boot on, step back in and set gap again.

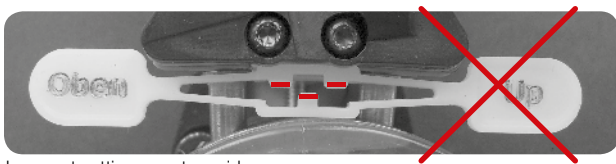

Incorrect setting: gap too wide.

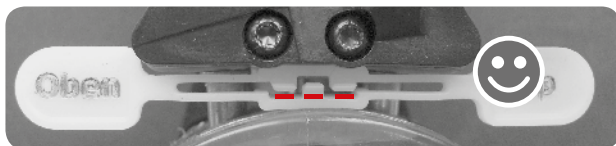

Correct gap setting. The 3 indicators line up straight.

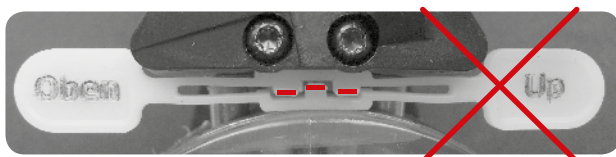

Incorrect setting: gap too narrow.

4.3 TOUR CLASSIC I TOUR CLASSIC DEMO

Binding assembly (TOUR CLASSIC)

Follow the assembling instructions for the front unit in point 4.2. TOUR Speed Lite binding and for the back unit in point 4.4. TOUR Freeride binding.

Binding assembly (TOUR CLASSIC DEMO)

Slide back the front unit on the rail and tighten the front screws of the rail.



Slide the front unit forward and tighten the back screws of the rail.

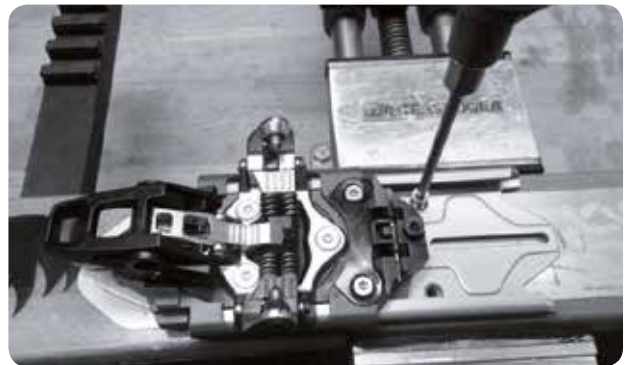

Bring the front unit into required positions and tighten the locking screw in the middle of the front unit.

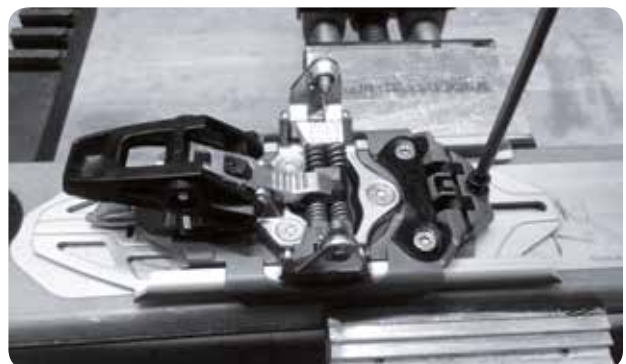

For the assembling of the back unit follow the instructions in point 4.2. TOUR Speed Lite binding.

Adjustment of toe piece

Open the forward lever to release the slide, and move it until the middle of the boot and mid-ski are aligned. Lower the lever. Push/pull twice on the boot to ensure the lever is correctly fastened.

Heel piece

Follow the instructions in point 4.4. TOUR Freeride binding.

4.4 TOUR FREERIDE 14/16

Installation of the ski binding

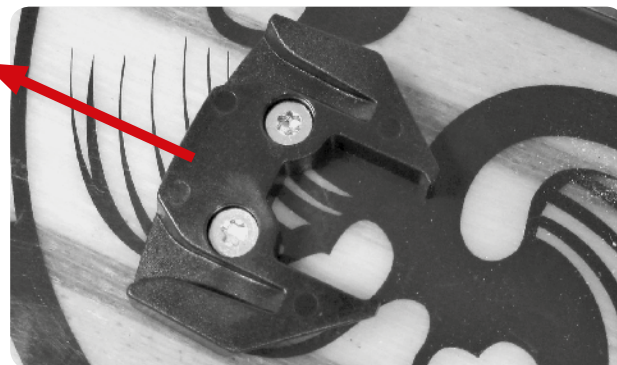

Direction of motion

First screw the safety catch of the toe piece to the ski manually .



Do not over-tighten the screws.

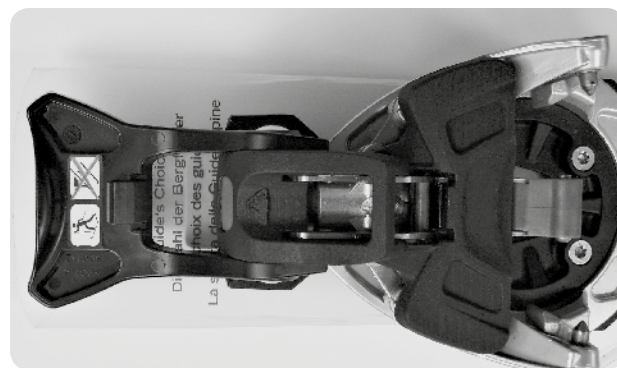

Screw on heel part and toe piece to the ski with the adjusting lever open.



Do not over-tighten the screws.

Mounting of back unit - see chapter 4.2 TOUR Speed Lite.

Setting the pressure

- Latch the ski shoe in the toe piece of the binding.
- Screw back the heel part at the pressure adjusting screw with PZ 3 until a gap forms towards the shoe insert.
- Latch the ski shoe in the heel piece.

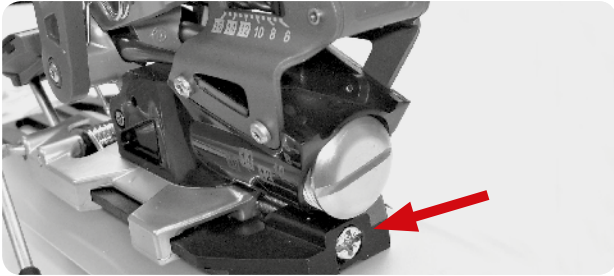

- Hold a paper strip of about 0.1 mm over the release bolt.
- Screw the heel piece to the shoe until the paper strip is caught.
- Then turn the screw back until the paper strip drops out.

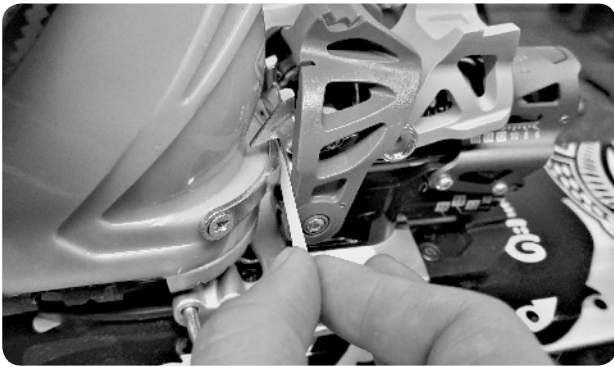

4.5 POWER INSERTS

Installing Power Inserts at the heel of the shoe

The Tour Freeride ski binding can only be used with ski shoes with "Power Inserts" at the heel. The heel of the ski shoe must comply with the specific specifications of DIN ISO 9523.

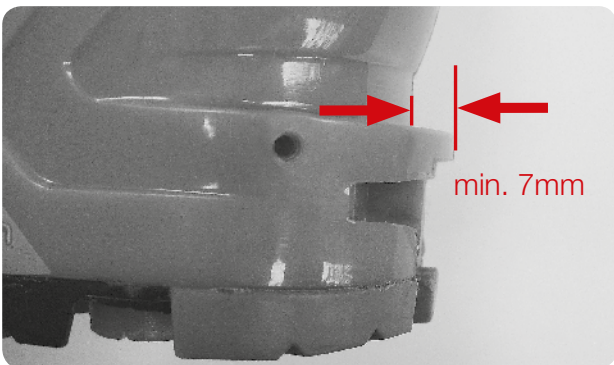

Attention: When mounted with a Power Insert, these boots are only compatible with Fischer Freeride system bindings.

Remove the present insert and manually screw on the Power Insert with the same screw.



Do not over-tighten the screw.

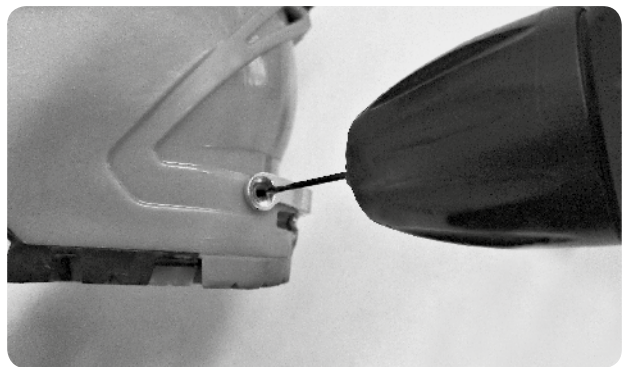

- Remove the inner shoe from the shell.
- Drill into the shoe at the insert holes with a \varnothing 2.5 mm drill to the stop.
- Turn in the two enclosed screws with a crosshead screwdriver.



Do not overtighten the screws!



5. ADJUSTING THE BINDING

Workshop certificate

As a Fischer certified dealer, you are required to keep accurate and complete records of all work performed on any Fischer ski binding. The workshop certificates must be collected and filed. The following data of the customer must be recorded on the workshop certificate:

- Name
- Age
- Sex
- All parameters required for determining the individual release torques MZ and MY and the numeric target values of these torques in Nm
- Skier type
- Sole length
- Ski boot type
- Ski binding type
- Ski type and ski length
- The Z values for all release functions for the right and the left ski as read on the testing device according to DIN/ISO 11088 after the adjustment.
- The scale value read on the ski binding
- Different settings requested by the customer, as well as +3, -1 or asymmetrical settings. Always have these changes signed off by the client on the certificate.
- Date of the adjustment

Handing over the functional unit and the setting card to the customer

Once the final adjustment has been completed, the customer/skier must receive the functional unit together with the fully completed workshop certificate (duplicate).

The customer should receive instructions on the use of the ski binding, in particular correct entry and exit, in the salesroom or when collecting the skis.

Important: One of the most important points for the responsible Fischer dealer is to ensure that the customer is given the correct user instructions, workshop certificate and important recommendations. If possible, the customer should receive a demonstration and receive the following instructions.

5.1 TOUR SPEED LITE/CLASSIC/CLASSIC DEMO

Adjusting the release settings

The release settings of the lateral release and the forward release are adjusted at the heel piece.

- Refer to the table page 96 for adjustment of the forward release of the ski binding; use the 4 mm slot screw driver for adjustment.

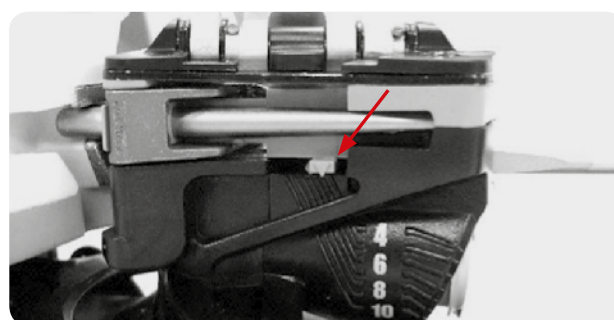

- Refer to the table page 96 for adjustment of the lateral release of the ski binding; use the 10 mm slot screw driver for adjustment.



CAUTION! To ensure the safety of the skier, the release setting must be determined and adjusted very carefully. All data indicated and the adjusted release setting must be entered in a workshop certificate.



The settings may not be lower than the lowest scale setting.



5.2 TOUR FREERIDE 14/16

Adjusting the release settings

- Upper screw – setting the frontal trigger with PZ3
- Middle screw – setting the side trigger with flat-tip screwdriver 10 mm



The settings of the ski binding are described on page 96.

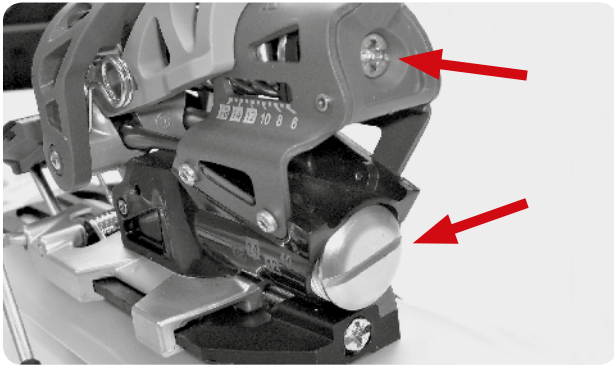

Attention! The ski stopper function on the Tour Freeride 16 is suitable for a stand height of up to 40 mm and a ski and binding weight of up to 2900 g.

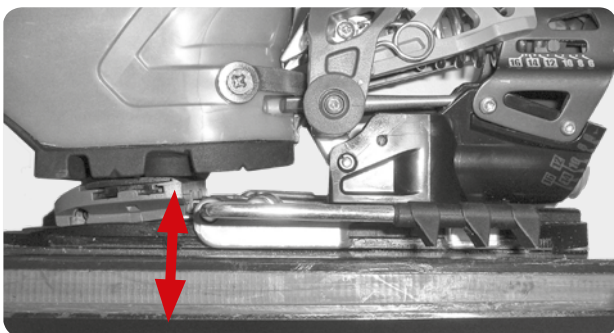

6. APPLIANCE

6.1 TOUR RACE LITE



Adjustment not conforming to standard, therefore there is no liability for the release settings!

- The eccentric lever is used to lock the binding for the ascent.
- If the boots are very narrow the plastic wedge which comes with the boots has to be inserted underneath the binding. This is necessary to ensure contact between the eccentric lever and the base plate for securing.



- The eccentric lever is properly secured when it clicks into position on the base plate with the boot in place.



Tour Race LITE w/o brake (Item No. T70016)

- When climbing, lock the excenter manually. This can be seen at the pressure piece in the tensioning fork.



Downhill mode

Climbing aid 1 at the heel piece open (deflected to the back).



Walking mode

Climbing aid 1 at the heel piece above the suspension fork (deflected above the release bolt).



Stepping out and stepping in see chapter 6.3.

6.2 TOUR SPEED LITE

Thread in ski leash at the loop at the excenter (lark's head knot).



Warning!! When attaching the ski leash to the ski boot, ensure that the leash loop cannot get hooked round the locking lever when binding is in walk mode.



See chapter 6.3 for stepping into the binding and usage of climbing tools.

6.3 TOUR CLASSIC

Characteristics of the Walk mode – ascent 0

Turn the heel piece by hand then press firmly on the brake pedal in order deactivate it.
Remove ice and dirt from shoe insert and binding, especially underneath the wings of the toe pieces.

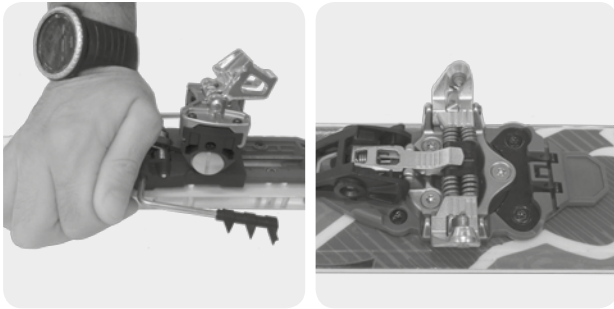

Stepping into the binding

- Push the excenter down with your ski pole to open the toe piece.
- Place the front end of the boot against the stoppers of the toe piece.
- Push down the front end of the boot so the pins engage in the front insert. Rotate the ski boot twice 2x to ensure proper closure of the toe piece.

Centre the toe piece partially before locking it.



- The excenters of the toe piece are locked.
- Climbing aids are folded in (downhill mode).
- Heel pins of the heel piece are not engaged.
- Brake is locked.

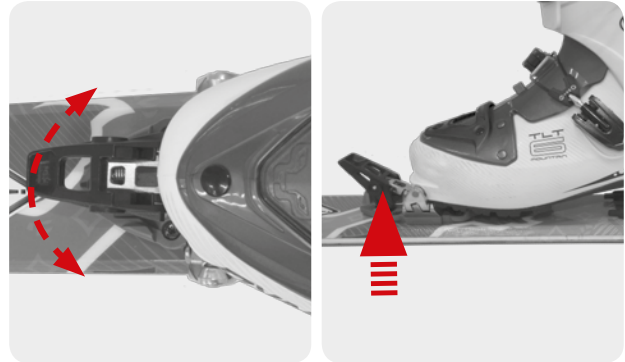

Climbing aids

- Flip the climbing aids with the ski pole
- 16.7 Climbing Aid 1 on
- 16.8 Climbing Aid 2 on

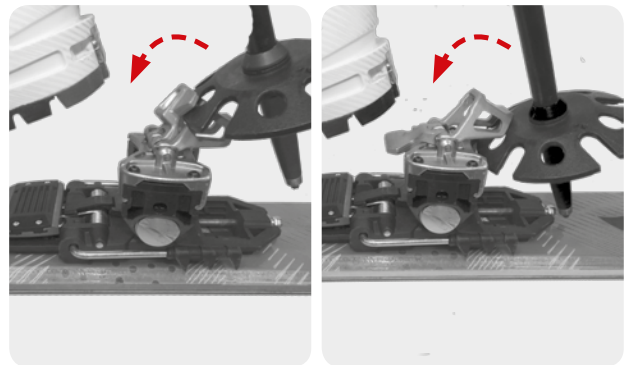

- Climbing Aid 2 off
- Climbing Aid 1 off

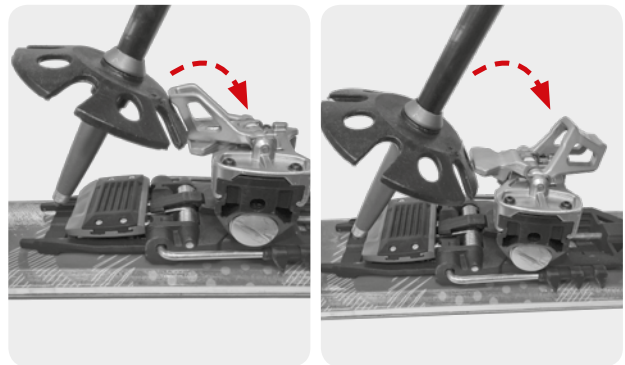

Characteristics of the walk mode – ascent 1

- The excenters of the toe piece are locked.
- Climbing aid 1 is on.
- Heel pins of the heel piece are not engaged.
- Brake is locked.



Characteristics of the walking mode – ascent 2

- The excenters of the toe piece are locked.
- Climbing aids 1 and 2 are on.
- Heel pins of the heel piece are not engaged.
- Brake is locked.



Characteristics of downhill position

Turn the heel piece in the anti-clockwise direction to activate the brake.



 Beware of brake trigger release!



- Climbing aids are off (downhill mode).
- Heel pins of the heel piece are engaged in the boot.
- Brakes are in open.



Push the heel of the boot down to engage heel insert in the heel pins of the binding.



 The excenters of toe must not be closed.

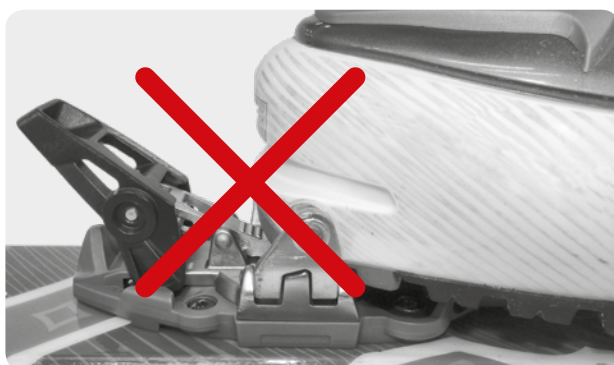

See page 26 for stepping out of the binding.

6.4 TOUR FREERIDE

6.4.1 Tour Freeride 14

Stepping in for ascent – Freeride 14

- Open the toe piece with your hand or ski pole.
- Step into the toe piece.
- Flip twice to remove any ice residue from the shoe inserts.
- Rotate the locking lever to a vertical position to lock the toe piece.

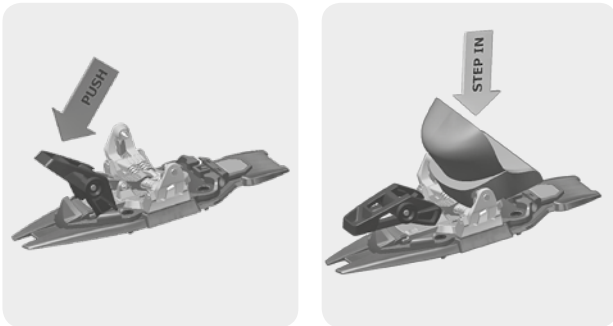

Always leave the toe piece's adjustment lever open for the ascent.

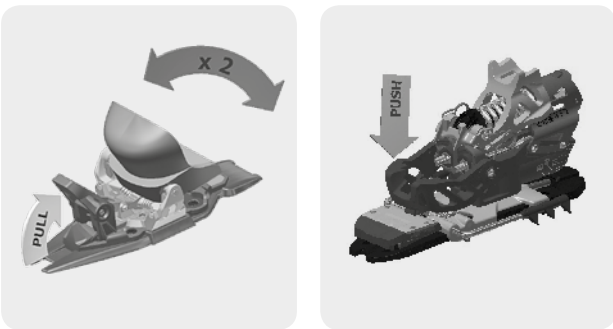

Operation of the climbing aid 2

- Climbing aid 1 = walking position
- Operate climbing aid 2 with the ski pole or with your hand.

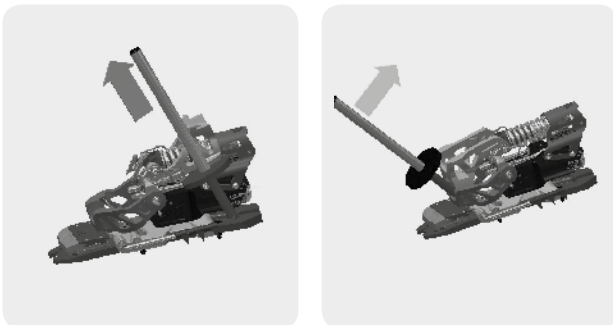

Stepping out of the binding

- Flip the locking lever back into a horizontal position.
- Open the toe piece with your hand or ski pole.
- Lift the tip of the shoe and step out to the right or left.

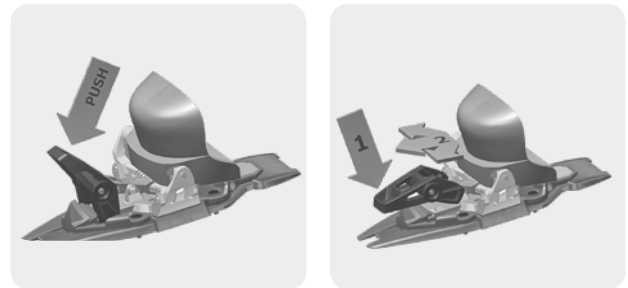

Stepping in for downhill skiing

- Open the climbing aid with the ski pole or your hand and flip it back.



The brake is activated.

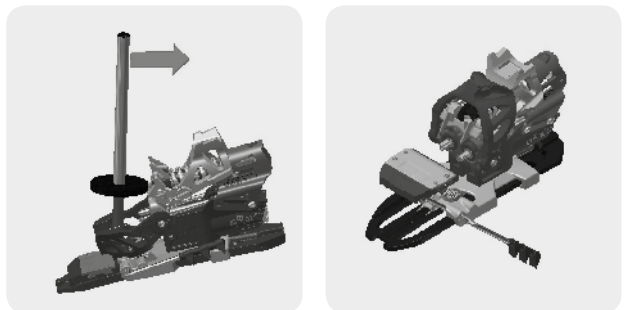

- Open the toe piece with the ski pole or your hand.
- Step into the toe piece.

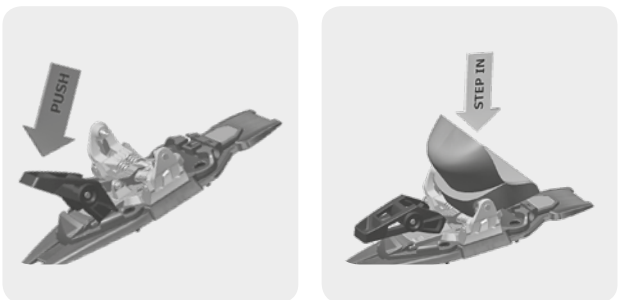

- Rotate twice to remove any ice residue from the shoe inserts.
- Then step into the heel piece and check that the pins are placed correctly in the heel insert.

Always leave the toe piece locking lever in horizontal position for downhill skiing.

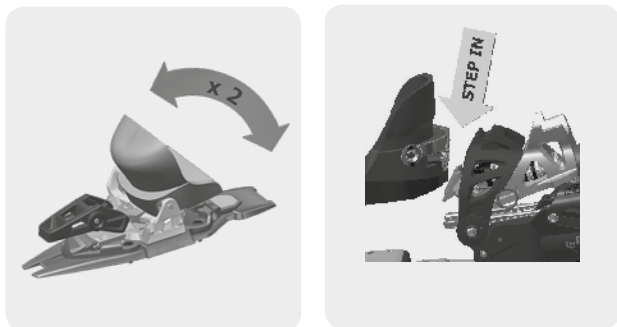

6.4.2 Tour Freeride 16

Stepping in for ascent – Freeride 16

- Open the toe piece with your hand or ski pole.
- Open the toe piece's adjusting lever.
- Step into the toe piece.
- Rock twice to remove any ice residue from the shoe inserts.
- Fold the climbing aid 1 into the walking position.
- Push down the climbing aid 1 with the shoe or with your hand until it latches.



Always leave the toe piece's adjustment lever open for the ascent.

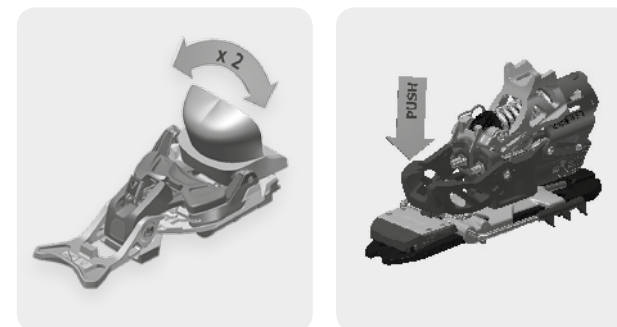

Operation of the climbing aid 2

- Climbing aid 1 = walking position
- Operate climbing aid 2 with the ski pole or with your hand.

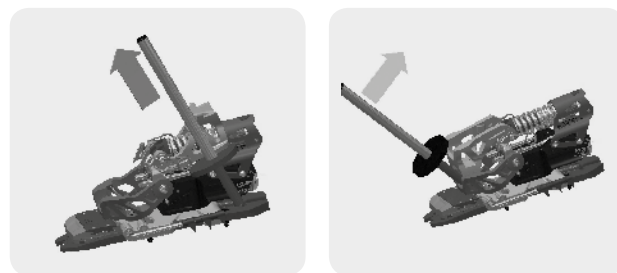

Stepping out of the binding

- Close the adjusting lever of the toe piece.
- Open the toe piece with your hand or ski pole.
- Lift the tip of the shoe and step out to the right or left.

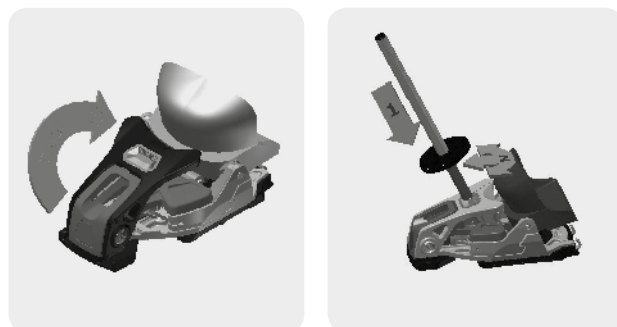

Stepping in for downhill skiing

- Open the climbing aid with the ski pole or your hand and fold it back.



The brake is activated.

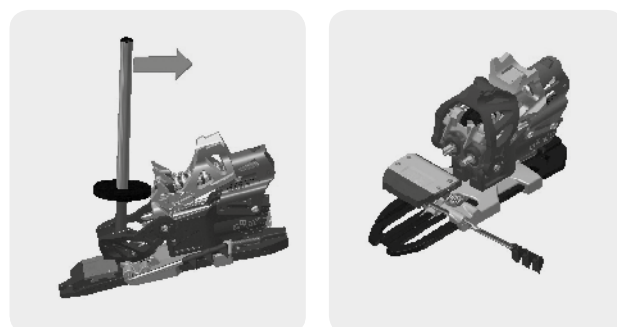

- Open the toe piece with the ski pole or your hand.
- Step into the toe piece.

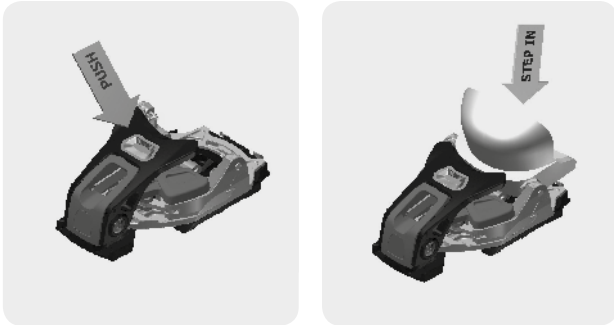

- Rock twice to remove any ice residue from the shoe inserts.
- Then step into the heel piece and check that the pins are placed correctly in the heel insert.

Always leave the toe piece locking lever in horizontal position for downhill skiing.

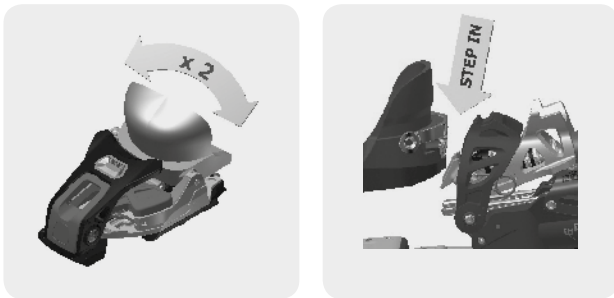

6.5 CRAMPON

Assembly and disassembly of the crampon

- Open crampon and insert it laterally into the crampon link at the toe.
- When folded down, the crampon is aligned centrally to the ski.
- To disassemble, perform in reverse order.

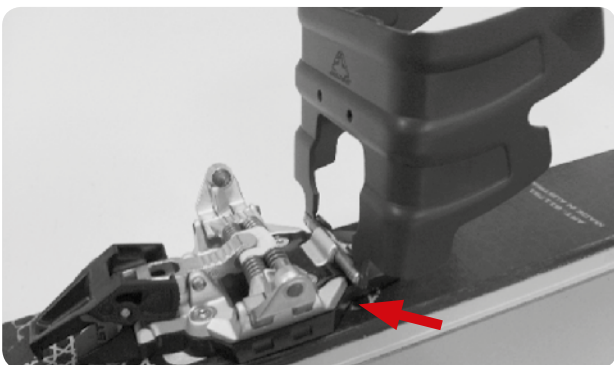

Important information for the customer!

- Only use original Fischer crampons
- Only use in hard snow when climbing up, not on rocks and bare ice.



Attention: Crampons are non-standardized products which are therefore not required to comply with national or European technical safety directives. Please follow the guidelines contained in the user instructions.

7. ACCESSORIES

7.1 DEMO PLATES TOUR RACE LITE

Adjustment plates for length adjustment

- Select required sole length on the included templates, adjust exactly with the ski midsole mark and glue on.



Ensure straight axial alignment.

Item No. T76416 Demotrack Tour Race LITE



- Drill according to drilling pattern .
- Remove template.



- Using the supplied screws (metric thread) and nut, screw binding on the adjustment plates.



Moment of force 5 Nm

- Fasten adjustment plate with the screwed on binding on the ski.
- Fasten binding as described in chapters 4.1.

7.2 SCREWS

	Ref.	Heel	Toe
	19mm TX20	Tour Freeride 16	
	T78615 15,75mm TX20	Tour Classic	Tour Freeride 16 Tour Freeride 14 Tour Classic Tour Classic Demo
	T78415 12,5mm TX20	Tour Race Tour Speed Lite Tour Freeride 16 Sicherung Stück (F6578)	Tour Race
	T78515 16,5mm TX 20		Tour Speed Lite
	10,5mm TX20	Tour Classic Demo	

8. MAINTENANCE

8.1 Lubricating the heel piece

- Remove housing from the base
Radical 1 - Replace housing and base with brakes
Open the lateral release adjustment screw with the 10 mm slot screwdriver. Carefully remove spring pack. Use snap ring pliers to remove spring sleeve from the housing.

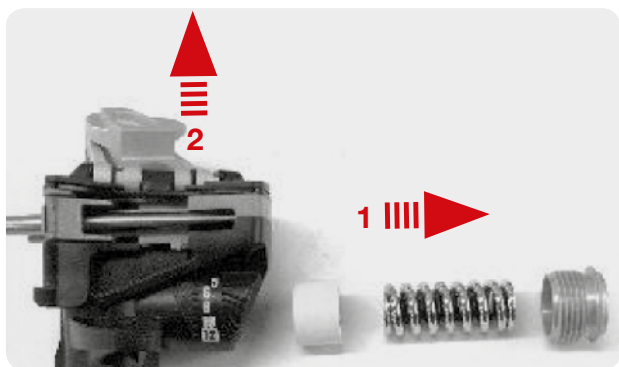

- Removing the housing from the base.

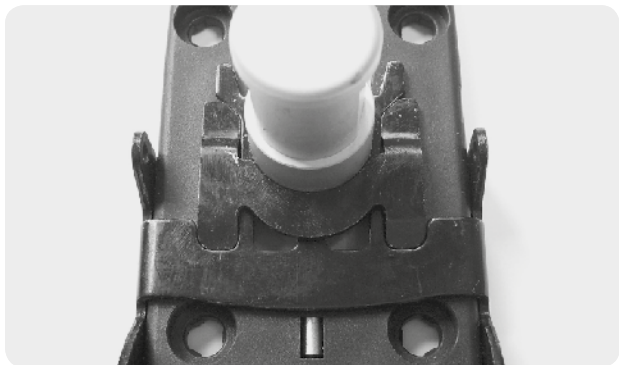
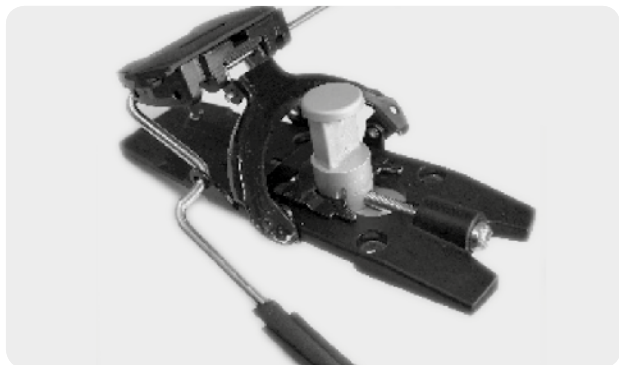

- Press in limiter pin and push the housing onto the axis up to the stop.
- If necessary, lubricate spring sleeve with PG 75 and insert into the housing.
- Fit springs into each other and insert into the housing.

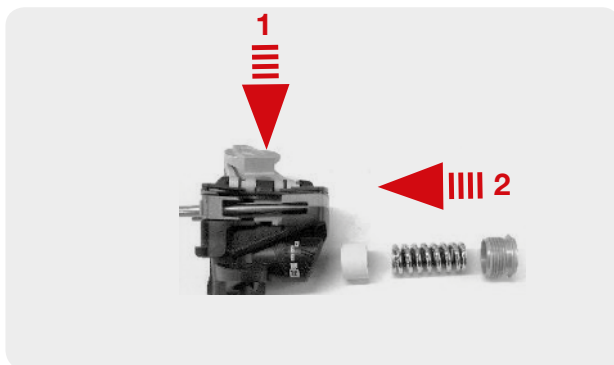

If a washer is fitted in the adjustment screw during disassembly, remember to refit it.



Perform adjustment as described in chapters 5.1.

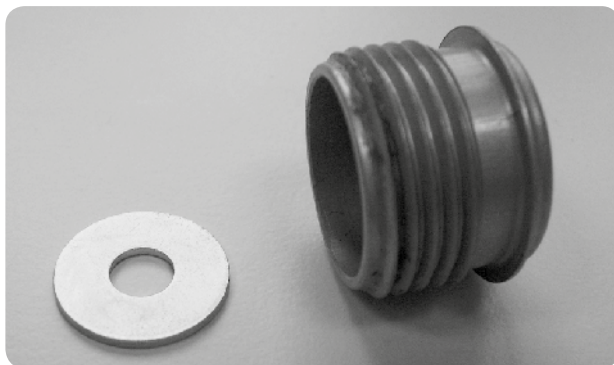

- Clean the surfaces of the axis, spring sleeve and closing plate that come into contact with the housing and lubricate them with PG75 grease.

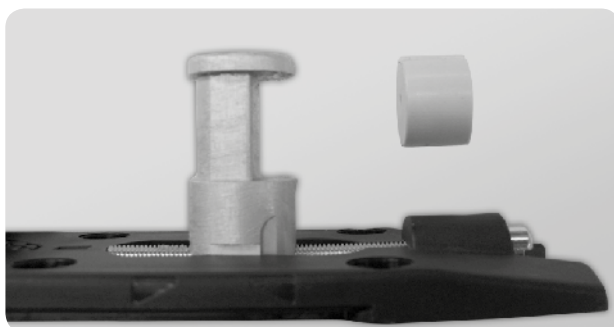

Lubricate surfaces of climbing aids that come into contact with the catch spring using Top 2000.

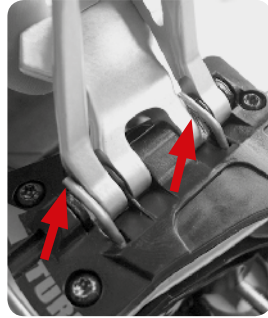
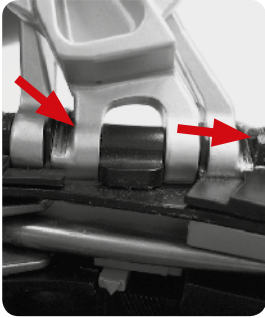

8.2 Lubricating the stopper pedal

Pull the gliding AFD on both sides up to the stop and lightly grease the guides with PG75.

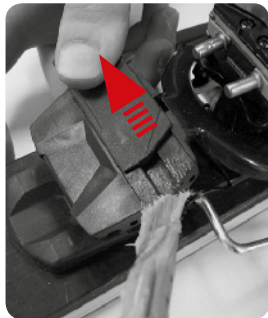
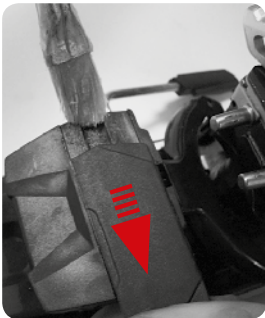

A NEW DECADE SERIES

The new Fischer AAADRENALIN, AAAMBITION, AAATTACK bindings are designed to explore every mountain. No matter if you tackle pristine slopes, untracked backcountry or even park and half pipe – overcome boundaries and ACCESS ALL AREAS!



THE TOURING NEWCOMER

The new Fischer AAAMBITION Alpine Touring binding is what every ski touring fanatic was looking for. On one hand it offers freedom and individual adjustment possibilities and on the other hand it provides the premium high-end performance that is expected from Fischer. The solid, light-weight construction and its maximum functionality enhances the -Overcome boundaries ultimate mountain experience for ambitioned climbers as well as for touring newbies. Overcome boundaries – Simply just: Access All Areas!

AAAMBITION 10 w/o brake

Stand Height: 38 mm
 DIN: 3 - 10
 Boots: Alpine & Touring boots
 Weight: 1790 g (*1960 g)
 Features: AT (Alpine Touring) Toe
 AFS, Telescopic tube
 AT (Alpine Touring) Heel
 Climbing Aid, Solid Colored
 Art. No.: T70114 – Solid white/black



THE PERFECT ALL-ROUNDER

The AAADRENALIN binding is a perfect option for freeriders who prefer precise downhill control combined with ideal mechanics for short walks to reach untouched paths for a memorable ski experience. Designed together with freeskiers and backcountry skiers, this member of the Fischer AAA-Series is designed for ski widths from 80 mm and wider. The AAADRENALIN brings paramount freeride performance in every terrain, on every slope. Whether skiing downhill or bridging walking paths, the Fischer AAADRENALIN gives adventurers an unrivaled combination of skiing performance and all terrain versatility. Overcome boundaries – Simply just: Access All Areas!

AAADRENALIN 13 w/o brake

Stand Height: 39 mm
 DIN: 4 - 13
 Boots: Alpine & Touring boots
 Weight short: 2390 g (*2690 g)
 Weight long: 2420 g (*2720 g)
 Features: FR Pro Toe, AFS Metal
 FR Pro Platform, FR Heel
 Climbing Aid, Solid Colored
 Art. No.: T16113 Short – Solid black/white
 T16213 Long – Solid black/white



ASTONISHING PARK & PIPE ACTION

Freeskiers prefer equipment which provides control, performance and usability. Not only for clear slopes and untracked powder areas, also for stoked park and half pipe rides. The new AAATTACK binding by Fischer combines functionality and modern design to meet these demands. A perfect tool for all-around skiers who are willing to attack! AAATTACK the track with this brand new Fischer freeski binding! Overcome boundaries – simply just: Access All Areas!

AAATTACK 16 w/o brake

Stand Height: 17 mm
 DIN: 5 - 16
 Boots: Alpine boots only
 Weight: 1830 g (*2130 g)
 Features: FR Pro Toe, AFD Metal
 Race Pro Heel, Solid Colored
 Art. No.: T16313 – Solid black/white

AAATTACK 13 AT w/o brake

Stand Height: 24 mm
 DIN: 4 - 13
 Boots: Alpine + Tour Norm
 Weight: -
 Features: Full Diagonal Toe, FRP, AFS,
 Alpine + Tour Norm
 Art. No.: T16416 – Solid black/white, w/o brake
 Full AT adjustability also in the Freeski/Freestyle AAAttack line. The new AAAttack 13 AT toe fits alpine, walking and touring ski boots.

AAATTACK 13/11 DEMO w/o brake

Stand Height: 42 mm/31 mm
 DIN: 4 - 13/3-11
 Boots: Alpine boots only
 Weight: 2250 g/2350 g
 Features: FR Pro Toe
 AFD Metal, One Touch Race Heel
 Sympro Heel Track
 Demo & Rental suitable, Solid Colored
 Art. No.: T90014 – Solid black/white/
 T90216 - Solid black

AAATTACK 11 w/o brake

Stand Height: 21 mm
 DIN: 3 - 11
 Boots: Alpinenorm
 Weight: 1360 (1660)g
 Features: Full Diagonal Toe, FRP, AFS
 AFD Metall
 Art. No.: T61015 – Solid black/white



THE TOURING NEWCOMER

The brand new Fischer AAAMBITION Alpine Touring binding is the perfect companion for all Alpine Touring Aficionados so that no terrain remains unattainable. We included every attribute of our high-performance alpine ski bindings in this brand new Alpine Touring binding.

ALPINE TOURING TOE:

This newcomer in the ski touring segment features the exclusive Fischer Alpine Touring (AT) Toe which can be easily adjusted to alpine and touring boot norms. A 65 mm wide mechanical AFS gliding element secures constant release values also with rubber soles. In combination with two rollers this binding provides superior safety features with the rapid and exact boot re-centering that skiers expect from Fischer.



As a result of its harmonious design, the Fischer AAAMBITION has a wider contact area which improves stability and provides a secure foundation for every skiing situation. Furthermore, its pivot is efficiently positioned right below the ski boot tip to ensure perfect force transmission and a tilt up to 90 degree.



ONE-FOR-ALL EASY ADJUSTABLE TELESCOPIC TUBE:

Additionally the AAAMBITION features a unique light-weight telescopic tube which offers an easy adjustment opportunity to different boot sole lengths. Thus, with only one binding model it is possible to cover the entire range of different sole lengths – from 260 mm up to 350 mm.

Furthermore, with the setting of the telescopic tube and through the compact mounting, perfect binding positioning on your skis is improved and midpoint deviation is avoided.



FISCHER FREEFLEX:

The FISCHER approved Freeflex System, which interacts with the AT Toe, the telescopic tube and the AT Heel, offers natural dynamics, excellent downhill performance and therefore a supreme ski touring experience.

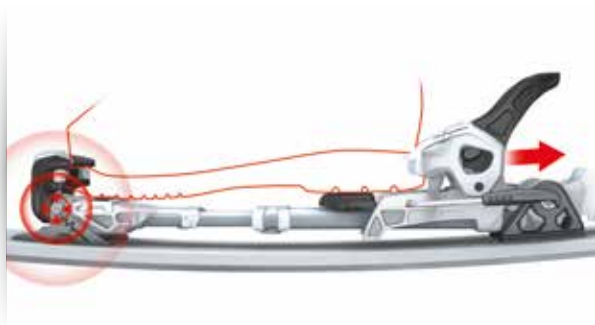

CRAMPONS:

Additional crampons are available as spare parts in widths of 90 mm, 105 mm and 120 mm, and provide safe climbing and a secure stand in any situation.

90 mm: Art. No. T163006 (1 Pair)

105 mm: Art. No. T163007 (1 Pair)

120 mm: Art. No. T163008 (1 Pair)



ALPINE TOURING HEEL AND CLIMBING AID:

The newly designed climbing aid is positioned as close as possible to the Alpine Touring (AT) Heel. This provides better walking balance and effortless climbing in all situations. The low stand height of 38 mm improves stability and offers a confident stance. With four different climbing aid positions (climbing in a 0°, 5°, 10° or 15° position) it is possible to adapt on different terrains without stepping out of the binding.



It does not matter if it is a walk through flat terrain or a steep slope up to the summit. Simply use the ski pole in order to change the climbing aid position and also to lock for the downhill ride.



DEMO AND RENTAL SUITABLE:

In order to offer ambitious sportsmen an opportunity to widen their horizons, the Fischer AAAMBITION is also demo and rental suitable.



Combined with a spare demo track (Art. No. T163001 AAAMBITION Demo Track-1 Pair), this brand new FISCHER binding can be tested and shown to a broad audience. Only two easy adjustments (one on the telescopic tube and one on the demo track) are required to fit to different boot lengths without extra drilling.



BRAKES & INDIVIDUALITY:

Considering the different ski widths, the FISCHER AAAMBITION comes without brakes. This gives you the opportunity to either choose the perfect fitting brake out of three different widths (85 mm/95 mm/105 mm/125 mm) or simply to ride and hike without brakes using appropriate powder straps.

- 85 mm Art. No. T163003 (1 Pair)
- 95 mm Art. No. T163016 (1 Pair)
- 105 mm Art. No. T163004 (1 Pair)
- 125 mm Art. No.:T163005 (1 Pair)



Powder Strap AAA-Series Art. No. T162981 (1 Pair)



Adrenalin

THE PERFECT ALL-ROUNDER

With the new AAADRENALIN Freeride binding from FISCHER, no terrain is out of reach. This binding provides a level of skiing performance never before seen in an alpine binding. It combines performance driven freeride features with the ultimate ergonomic walking mechanism for maximum freedom on-and off-piste. Overcome boundaries smoothly for a perfect ride.



FREERIDE (FR) PRO TOE:

The FISCHER AAADRENALIN comes with the Freeride (FR) Pro Toe with its ergonomic pivot position for optimal tilt up movement up to 90 degrees. This system provides effortless walking over short distances.



The FR Pro Toe is adjustable by changing the position of the Anti-Friction-Slider (AFS Metal) to cover alpine and touring boot norms. The AFS-metal FR PRO Slider is available as a spare part Art. No. T162984.

This 68 mm wide slider plus a stainless steel gliding element provide constant release values and result in a broader contact area to the ski boot sole. The benefits: more stability, more direct power transmission and an ultimate skiing performance.

FREERIDE (FR) PRO HEEL:

The ultra-wide 80mm heel track makes all the perfor-

mance difference needed to take this product over the top. Extra width and the superior kinematics of FISCHER's high performance bindings make it absolutely stable and reliable for perfect force transmission and unmatched performance. The heel can easily be adjusted to different boot sole lengths without any additional tools. It covers a wide range of seven ski boot sizes. The AAADRENALIN freeride binding is available in two lengths:

SHORT (S) for ski boot sole length of 270 – 330 mm

LONG (L) for ski boot sole length of 300 – 360 mm



CRAMPONS:

Additionally, FISCHER crampons (available as spare parts in three widths: 90 mm, 105 mm and 120 mm) can be mounted to improve grip in steep and icy terrain.

90 mm: Art. No. T162977 (1 Pair)

105 mm: Art. No. T162978 (1 Pair)

120 mm: Art. No. T162979 (1 Pair)



BRAKES & INDIVIDUALITY:

The FISCHER AAADRENALIN comes without brakes. This gives each freerider the chance to choose the precisely fitting brakes in regard to the ski widths. The AAADRENALIN 16 can be combined with brake widths of 88 mm, 97 mm, 115 mm or 130 mm. Brakes with a width of 88 mm, 97 mm or 115 mm can be installed on the AAADRENALIN 13. To find the right brake to your AAADRENALIN have a look to the FISCHER brake line overview.



FISCHER FREEFLEX:

The platform of FISCHER's AAADRENALIN binding provides the approved FISCHER Freeflex function which allows the ski to flex as it is designed to do so it can retain its natural dynamics. Freeflex is enabled by the free gliding plate that runs within the titanal heel track and is supported by the center of rotation of the binding toe.



AAA ASCENDER LOCK AND CLIMBING AID:

To Access All Areas, transition from skiing to hiking is incredibly fast, easy and convenient. Simply use the tip of the ski pole without stepping out of the binding to move the highly visible Ascender Lock to change between hiking and ski mode.

Another FISCHER feature is the possibility to walk in the 0° position. After release, FISCHER's climbing aid can easily be operated with a ski pole and it can be positioned in three different angles (0°, 7° and 13°) for an optimal walking position. This improves balance and a secure stand on your way to perfect skiing spots. The climbing aid is also available as a spare part (Art. No. T162982).

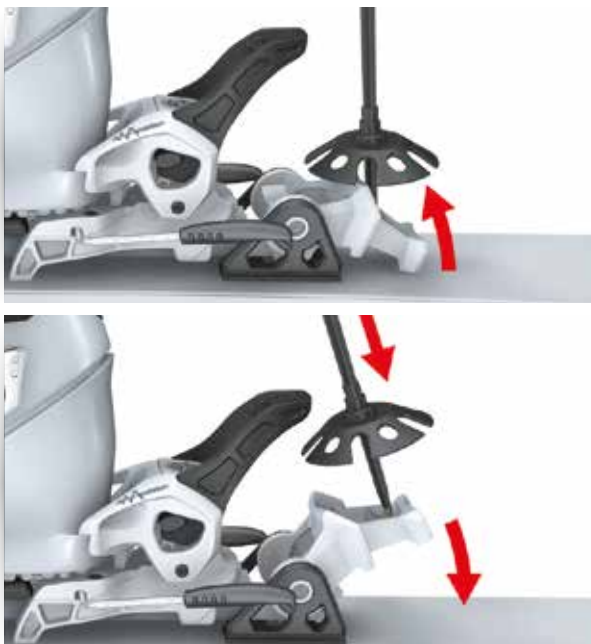

SPARE PART:
Powder Strap AAA-Series Art. No. T162981 (1 Pair)



ASTONISHING PARK & PIPE ACTION

The new AAATTACK binding, designed for freeskiers, captivates with its minimalistic design, and combines perfect light-weight control and versatile usage in one masterpiece. With this new freeski binding you can enjoy park or half pipe just as high performance off-piste skiing. A perfect tool for allride skiers who are willing to attack! Get ready for park, half pipe & on-and off-piste with the FISCHER AAATTACK binding models:

MODERN ARCHITECTURE:

The special Freeride (FR) Pro Toe with its horizontal spring reflects the modern architecture of the new FISCHER AAA-Series. Furthermore, it includes a super secure 77 mm metal friction device (AFD Metal), which can be adjusted for all types of alpine boots (Type A only). The AAAT-

TACK 16 features the FISCHER Race Pro Heel, with a reduced stand height of only 17 mm for the ultimate freeski adventure.



PERFECT INDIVIDUALITY:

The built in AAA-Series technology ensures high quality and perfect usability. In regard to its clear design and its compact measurement, the AAATTACK model can be ideally used on ski widths from 80 mm and wider. FISCHER's brand new designed AAAttack binding is available in two different DIN settings (16 and 13). The AAATTACK 13 features a solid construction, reduced weight and a new designed Heel, which brings this model to a new level. Some models are delivered without brakes. This gives riders the opportunity to customize the setup to their needs. Brakes are available in different widths: 88 mm, 97 mm, 115 mm, 130 mm and 150 mm. Find Art. No. of all brakes at FISCHER brake line overview.



DEMO & RENTAL SUITABLE:

The Fischer AAAttack 13 DEMO model, a modified version of the Fischer AAAttack Freeski binding, is the first demo and rental suitable freeski binding that is anchored on a metal toe track. This unique feature ensures a lower stand height, a more compact design and increased stability compared with other bindings. In combination with the proven Fischer Rental Heel track, the Fischer AAAttack 13 DEMO offers the opportunity to fulfill every customer's desires, whether for retail, demo or rental purposes. This easy to adapt Fischer AAAttack Freeski binding model was designed for a wide range of sole lengths, and therefore can be adjusted to all available alpine boot sole lengths from 259 to 386 mm – tool-free in a matter of a few seconds, by moving the toe and heel pieces. The DEMO range of the AAA-series was enriched by the AAAttack 11 Demo model, to provide „Access All Areas“ for as many skiers as possible. DEMO models are now available for DIN 4-13 (AAAttack 13 Demo) and DIN 3-11 (AAAttack 11 Demo).

SAFETY FEATURES

ONLY PERFECTION PROVIDES SAFETY

FISCHER has dedicated itself especially to Active Safety as a core characteristic. Unique safety features, such as the exclusive FISCHER ABS band and FISCHER Diagonal Heel offer optimal all-around protection for every skier.

TRP TOE SYSTEM

The FISCHER Roller Pincer – Toe System (TRP System) of the FISCHER bindings with its four rollers and gliding inserts ensures a 180° release and exact centering of the ski boot. The TRP system reduces the load on knees and ligaments and improves performance considerably.



RACE DIAGONAL VS. FULL DIAGONAL TOE

Race Diagonal:

Diagonal Toe tuned for racing purposes. Due to its higher release force vertically than horizontally, it holds up to the high backward lean forces in racing.

Full Diagonal:

Intelligent 180° release both horizontally and vertically of the Diagonal Toe and therefore maximum safety in backward twisting-fall situations.

ABS - ANTI BLOCKING SYSTEM

The exclusive FISCHER technology of the ABS continuous band allows the boot to move out of the binding almost without any friction, hence delivering maximum safety in case of icing up, dirt and boot wear.



RACE PRO HEEL

The stand height is according to the current FIS rules. An increased contact area reduces friction and provides constant forward pressure in all skiing situations.



FREEFLEX PRO

Best performance enabled by the new, innovative Freeflex Pro System. The free-gliding heel allows the ski to bend through unimpeded and to retain its natural dynamics. Due to the reduced stand height, the Freeflex band is now much closer to the ski boot. Constant release values reduce the risk of injury and ensure safe ski steering.



BINDING LINE UP 16I17

Model	Artical No.	Ramp Angle	Z - DIN	kg	lbs	Weight	Drill template	Toe		
								Toe type	Toe System	AFD
RACE										
RC4 Z 20 FF X Race Service (RD) BRAKE 85 [A]	T00115	3,5	10-20	from 97	from 209	3190	92 W	RACE	-	RACE AFD
RC4 Z 20 FF X Race Service (RS) BRAKE 85 [A]	T00215	3,5	10-20	from 97	from 209	3190	92 W	RACE	-	RACE AFD
RC4 Z 18 FF X Race Service BRAKE 85 [A]	T00315	3,5	8 - 18	from 79	from 175	3170	92W	RACE	-	RACE AFD
RC4 Z 16 FF X Race Service (RD) BRAKE 85 [A]	T00415	3,5	8 - 16	from 79	from 175	3170	92W	RACE	-	RACE AFD
RC4 Z 17 Freeflex BRAKE 85 [A]	T00516	3,5	6 - 17	from 58	from 126	2690	92W	RACE	-	RACE AFD
RC4 Z 13 Freeflex BRAKE 85 [D]	T00616	4,0	4 - 13	from 42	from 92	2560	92W	RX	Full Diagonal	ABS
RC4 Z 11 Freeflex BRAKE 85 [D]	T00716	4,0	3 - 11	from 31	from 67	2350	92W	SX	Full Diagonal	ABS
C - LINE										
C-Line Z 13 RaceTrack BRAKE 85 [F]	T10116	4,5	4 - 13	from 42	from 92	2090	Bases & Plates	RX	Full Diagonal	ABS
HIGH PERFORMANCE										
RC4 Z12 Powerrail BRAKE 85 [F]	T20216	4,5	3,5 - 12	from 36	from 79	2070	Bases & Plates	SX	Full Diagonal	ABS
RSX 12 Powerrail BRAKE 85 [F]	T20416	4,5	3,5 - 12	from 36	from 79	2070	Bases & Plates	SX	Full Diagonal	ABS
SPORT PERFORMANCE										
RC4 Z11 Powerrail BRAKE 78 [G]	T40016	7,0	3 - 11	from 31	from 67	1770	Bases & Plates	SX	Full Diagonal	AFS
RS11 Powerrail BRAKE 78 [G]	T40115	7,0	3 - 11	from 31	from 67	1770	Bases & Plates	SX	Full Diagonal	AFS
RS11 Powerrail BRAKE 78 [G]	T40126	7,0	3 - 11	from 31	from 67	1770	Bases & Plates	SX	Full Diagonal	AFS
RS10 Powerrail BRAKE 78 [G]	T40315	7,0	3 - 10	from 31	from 67	1770	Bases & Plates	SX	Full Diagonal	AFS
RS10 Powerrail BRAKE 78 [G]	T40415	7,0	3 - 10	from 31	from 67	1770	Bases & Plates	SX	Full Diagonal	AFS
RS10 BRAKE 78 [E]	T40715	9,0	3 - 10	from 31	from 67	1620	92W	SX	Full Diagonal	Teflon
RS9 SLR BRAKE 78 [H]	T41016	5,5	2,5-9	from 26	from 57	1400	SLR & LR	SX Lite	Full Diagonal	AFS Jr.
RS9 BRAKE 78 [J]	T41216	9,0	2,5-9	from 26	from 57	1440	92W	SX Lite	Full Diagonal	AFS Jr.
WOMEN MY STYLE										
W 10 Womantrack BRAKE 78 [H]	T50115	5,0	3 - 10	from 31	from 67	1640	SLR & LR	SX	Full Diagonal	AFS
W 9 AC SLR/Womentrack BRAKE 78 [H]	T51116	5,5	2,5 - 9	from 26	from 57	1420	SLR & LR	SX Lite	Full Diagonal	AFS Jr.
JUNIOR										
RC4 Z9 BRAKE 78 [J]	T80016	5,0	2,5 - 9	from 26	from 57	1480	92W	SX Lite	Full Diagonal	AFS Jr.
FJ7 AC W/O BRAKE [J]	T80715	9,0	2 - 7,5	22-84	48-187	1100 (1400)	92W	SX Jr.	Full Diagonal	AFS Jr.
FJ7 AC BRAKE 78 [J]	T80116	9,0	2 - 7,5	22-84	48-187	1400)	92W	SX Jr.	Full Diagonal	AFS Jr.
FJ7 AC SLR BRAKE 78 [H]	T80216	5,5	2 - 7,5	22-84	48-187	1360	SLR & LR	SX Jr.	Full Diagonal	AFS Jr.
FJ7 AC SLR BRAKE 78 [H]	T80316	5,5	2 - 7,5	22-84	48-187	1360	SLR & LR	SX Jr.	Full Diagonal	AFS Jr.
FJ7 AC SLR BRAKE 78 [H]	T80416	5,5	2 - 7,5	22-84	48-187	1360	SLR & LR	SX Jr.	Full Diagonal	AFS Jr.
FJ4 AC BRAKE 74 [K]	T80515	3,0	0,75 - 4,5	10-48	22-105	1190	94W	SX Kid	Full Diagonal	AFS Jr.
FJ4 AC SLR BRAKE 74 [I]	T80616	5,5	0,75 - 4,5	10-48	22-105	1250	SLR & LR	SX Kid	Full Diagonal	AFS Jr.
FJ4 AC SLR BRAKE 74 [I]	T80816	5,5	0,45 - 4,5	10-48	22-105	1250	SLR & LR	SX Kid	Full Diagonal	AFS Jr.
FREESKI										
ADRENALIN 13 SHORT W/O BRAKE [F]	T16113	4-10,5	4-13	from 42	from 92	2420 (2720)	AAADRENALIN	FR PRO	---	AFS metal
ADRENALIN 13 LONG W/O BRAKE [F]	T16213	4-10,5	4-13	from 42	from 92	2440 (2740)	AAADRENALIN	FR PRO	---	AFS metal
ATTACK 16 W/O BRAKE [A]	T16313	2-5	5-16	from 49	from 109	1830 (2130)	92 W / 92 FAT	FR PRO	---	AFD metal
ATTACK 13 AT W/O BRAKE [A]	T16416	2-6	4-13	from 42	from 92	1740 (2040)	92 W / 92 FAT	FR PRO AT	---	AFD metal
ATTACK 11 W/O BRAKE [L]	T61015	6-9	3-11	from 31	from 67	1360 (1660)	92 W / 92 FAT	FR PRO	---	AFD metal
TOUR										
AAAMBITION 10 w/o brake	T70114	3 (6)	3-10	from 31	from 67	895 (980)	Ambition	AT	---	AFS
Tour Race Lite w/o BRAKE	T70016	1	---	---	---	110	TEMPLATE RACE LITE	Low Tech	---	---
Tour Speed Lite W/O BRAKE	T70115	1	4-10	---	---	367	TEMPLATE SPEED LITE, RACE	Low Tech	---	---
Tour Classic BRAKE 90	T70215	1	4-10	---	---	599	TEMPLATE CLASSIC, FREERIDE	Low Tech	---	---
Tour Classic BRAKE 105	T70315	1	4-10	---	---	599	TEMPLATE CLASSIC, FREERIDE	Low Tech	---	---
Tour Classic BRAKE 120	T70415	1	4-10	---	---	599	TEMPLATE CLASSIC, FREERIDE	Low Tech	---	---
Tour Classic Demo BRAKE 90	T70515	0	4-10	---	---	599	TEMPLATE CLASSIC, FREERIDE	Low Tech	---	---
Tour Classic Demo BRAKE 105	T70615	0	4-10	---	---	599	TEMPLATE CLASSIC, FREERIDE	Low Tech	---	---
Tour Freeride 14 BRAKE 105	T70715	5	5-14	---	---	795	TEMPLATE CLASSIC, FREERIDE	Low Tech	---	---
Tour Freeride 14 BRAKE 120	T70815	5	5-14	---	---	795	TEMPLATE CLASSIC, FREERIDE	Low Tech	---	---
Tour Freeride 16 BRAKE 120	T71015	4	6-16	---	---	940	TEMPLATE CLASSIC, FREERIDE	Low Tech	---	---
RENT										
XTR 10 Pro BRAKE 78 [D]	T17811	5,0	2,5-10	from 26	from 57	2570	XTR Pro	SX OT	Full Diagonal	ABS
XTR 7 AC Pro BRAKE 78 [D]	T18013	5,0	1,5-7,5	18-84	39-187	2450	XTR Pro	SX Jr.	Full Diagonal	AFS Jr.
XTR 4 AC Rent BRAKE 74 [K]	T18612	1,5	0,75-4,5	10-48	22-105	1260	XTR Rent	SX Kid	Full Diagonal	AFS Jr.
ATTACK 13 DEMO W/O BRAKE [D]	T90014	1-4	4-13	from 42	from 92	2550	Attack Demo	FRP PRO OT	---	AFD metal
ATTACK 11 DEMO W/O BRAKE [D]	T90216	2,5-5,5	3-11	from 31	from 67	2350	Attack Demo	FRP PRO OT	---	AFD metal

		Heel					Boot Sole			
Stand Height	Length Adj. Range	Heel Type	Heel System	Brake	Brake Code	Stand Height	Length Adj. Range	Length (mm)	Standard	
12,5	---	RACE PRO (spindle)	Standard	PB ² Race Pro 16-85	A	16,0	32	255 - 375	Adult	
12,5	---	RACE PRO (spindle)	Standard	PB ² Race Pro 16-85	A	16,0	32	255 - 375	Adult	
12,5	---	RACE PRO (spindle)	Standard	PB ² Pro 16-85	A	16,0	32	255 - 375	Adult	
12,5	---	RACE PRO (spindle)	Standard	PB ² Pro 16-85	A	16,0	32	255 - 375	Adult	
12,5	---	RACE PRO	Standard	PB ² Race Pro 16-85	A	16,0	32	255 - 375	Adult	
17,0	---	D-RX	Diagonal	Power Bracke ² LD 85	D	21,0	24	257 - 372	Adult	
17,0	---	RACE Lite	Standard	Power Bracke ² LD 85	D	21,0	24	257 - 372	Adult	
29,0	60	D-RX	Diagonal	Powerrail Brake ² LD 85	F	33,5	60	257-380	Adult	
29,0	60	D-RX	Diagonal	Powerrail Brake ² LD 85	F	33,5	60	257 - 380	Adult	
29,0	60	D-RX	Diagonal	Powerrail Brake ² LD 85	F	33,5	60	257 - 380	Adult	
24,0	60	SX	Standard	Powerrail Brake SL 78	G	31,0	60	257 - 380	Adult	
24,0	60	SX	Standard	Powerrail Brake SL 78	G	31,0	60	257 - 380	Adult	
24,0	60	SX	Standard	Powerrail Brake SL 78	G	31,0	60	257 - 380	Adult	
24,0	60	SX	Standard	Powerrail Brake SL 78	G	31,0	60	257 - 380	Adult	
24,0	60	SX	Standard	Powerrail Brake SL 78	G	31,0	60	257 - 380	Adult	
12,0	---	SX	Standard	SL Brake 78	J	21,0	32 (-B/+24)	---	Adult	
21,5	40	SX Lite	Standard	SL Brake LR 78	H	27,0	40	S:199-283; M:239-323; L:263-347	A/C	
12,0	---	SX Lite	Standard	SL Brake 78	J	21,0	32 (-B/+24)	---	A/C	
23,0	40	SX	Standard	SL Brake LR 78	H	28,0	60	255 - 338	Adult	
21,5,0	40	SX Lite	Standard	SL Brake LR 78	H	27,0	40	S:199-283; M:239-323; L:263-347	A/C	
16,0	---	SX Lite	Standard	SL Brake 78	J	21,0	32 (-B/+24)	---	Adult	
12,0	---	SX Jr.	Standard	w/o Brake	J	21,0	32 (-B/+24)	---	A/C	
12,0	---	SX Jr.	Standard	SL Brake 78	J	21,0	32 (-B/+24)	---	A/C	
21,5	40	SX Jr.	Standard	SL Brake 78	H	27,0	40	S: 199 - 283 / M:239 - 323/ L: 263 - 347	A/C	
21,5	40	SX Jr.	Standard	SL Brake 78	H	27,0	40	S: 199 - 283 / M:239 - 323/ L: 263 - 347	A/C	
21,5	40	SX Jr.	Standard	SL Brake 90	H	27,0	40	S: 199 - 283 / M:239 - 323/ L: 263 - 347	A/C	
12,0	---	SX Kid	Standard	SX Kid Brake 74	K	15,0	44	---	A/C	
21,5	40	SX Kid	Standard	SX Kid Brake LR 74	I	27,0	40	S: 199 - 283 / M:239 - 323/ L: 263 - 347	A/C	
21,5	40	SX Kid	Standard	SX Kid Brake LR 74	I	27,0	40	S: 199 - 283 / M:239 - 323/ L: 263 - 347	A/C	
28,5-35,0	---	FR	Standard	---	F	39,0	60	270-330	A / T	
28,5-35,0	---	FR	Standard	---	F	39,0	60	300-360	A / T	
12-15	---	RACE PRO	Standard	---	A	17,0	32	---	Adult	
18-22	---	Race	Standard	---	A	24,0	32	---	A / T	
12-15	---	SX	Standard	---	L	21,0	32 (-B/+24)	---	Adult	
35	---	AT	Standard	---	C	38 (*41)	14	260-350	A / T	
5	---	Low Tech	---	---	---	6	---	---	---	
11	---	Low Tech	---	---	---	23	25	---	---	
19	---	Low Tech	---	---	---	29	45	---	---	
19	---	Low Tech	---	---	---	29	45	---	---	
19	---	Low Tech	---	---	---	29	45	---	---	
22	45	Low Tech	---	---	---	29	45	---	---	
22	45	Low Tech	---	---	---	29	45	---	---	
19	---	Low Tech	---	---	---	26	25	---	---	
19	---	Low Tech	---	---	---	26	25	---	---	
20	---	Low Tech	---	---	---	26	25	---	---	
26,0	64	Rent OT	Rental	Power Brake ² LD 85	D	31,0	60	263 - 391	Adult	
26,0	64	SX Jr.	Rental	Power Brake ² LD 85	D	31,0	60	215 - 343	A / C	
13,5	---	SX Kid OT	Rental	SX Kid Brake 74	K	15,0	52	199 - 255 (231 - 287)	A/C	
19-22	60	Rent OT	Rental	---	D	23,0	60	259 - 386	Adult	
24-27	60	SX	Standard	Powerrail Brake SL 90	G	29,5	60	259 - 382	Adult	

PRO-RENT SYSTEM 16I17

Performance, for a rental binding, is not only what happens on the hill. A key measure of a product's quality is the ease with which a system can be adjusted and maintained throughout the course of many seasons.

THE FISCHER'S SHOP FRIENDLY RENTAL DESIGN FEATURES:

- Easy mounting: This means fewer mistakes and reduced set-up time.
- Easy pre-season testing, low drop-out rate.
- The automatic sole lug design and the precise centering of the toe pincer system mean: fewer correction factors will be needed and less time spent testing.
- The SINGLE CODE system gives you a super fast option for binding-to-boot adjustment: set the heel length using the special sole length scale. Forward pressure will be right on, first time, every time.
- All models have automatic lug height adjustment which accommodate standard differences in boot sole-height.
- Easy, hand- levered "ONE TOUCH"- set up. One tool adjustment, easy to turn adjustment screw, "easy-in" boot feature.
- Almost maintenance-free, easy to change the AFD, clean and lubricate the heel track.

FISCHER made the commitment to offer a comprehensive product and service program.

THE FISCHER-RENTAL BINDINGS

No single rental binding can ever fulfill all the needs of all types of shops. We therefore offer the following line up of rental/demo models.

SYMPRO:

THE BINDINGS THAT HELP YOUR HIGH PERFORMANCE SKI SET-UP:

XTR 10 PRO

- Hand lever-adjusted heel (60 mm) and toe (64 mm)
- 7-toe positions
- DIN-ranges from 2.5 up to 13 that accommodate even high level skiers
- Short, lightweight heel track, despite wide adjustment range
- SINGLE CODE: "A-6" for ski boots from 263-391 mm sole length
- Replaceable brake
- Diagonal toe
- Optimal for Carving skis, minimized deviation between ski and boot mounting point



XTR 7 AC PRO

A child and junior model, super convenient, "parent-free" operation

- Automatic toe and heel pieces accept child and adult boot sole dimensions, giving you full utilization of your child/junior ski inventory
- SINGLE CODE "a-H" for ski boots from 191-294 mm sole length (SP 4.5 AC) and "f-U" for ski boots from 215-343 mm sole length (SP 7.5 AC) The Single Code in lowercase letter refers to children's boots, whereas with capital letter to type A boots (Adult)
- „ONE TOUCH“ hand lever adjustment for toe and heel
- Replaceable brake
- Diagonal toe.
- For skis, groups G3 & G4 (SP 4.5 AC)
- DIN range 0.75 up to 7.5

XTR 4 AC Rent

A child and junior model, super convenient, "parent-free" operation

- Automatic toe and heel pieces accept child and adult boot sole dimensions, giving you full utilization of your child/junior ski inventory
- SINGLE CODE
- "b-o" (199-255 mm) standard, or "j-w/F" (231-287 mm) with spare part: 162970
- "ONE TOUCH"- Hand lever adjustment of the heel
- Replaceable brake
- Easy to open, easy to close
- For skis, groups G3 & G4
- DIN range 0.75 up to 4.5

JUST ONE CLICK

See OMS System:

<http://spareparts.fischersports.com>

User: spare_fischer

Password: omsnew

The new Fischer OMS Spare Part Management offers all relevant information about ski bindings, technical data and their (spare) parts at a glance - and just one click away. Extensive information is available via the new OMS spare part system: Starting with the appropriate drill template right up to screws and spare parts related to a specific binding model; for example different brake types - plus, all parts can be directly identified by model. Pictures and coloured marks provide simple navigation tools and easy recognition of selected parts.

LOGIN

Type in <http://spareparts.fischersports.com>

User: spare_fischer

Password: omsnew

You may navigate through the Spare Parts OMS via two different modes:

1. Products
2. Spare Parts



TECHNICAL DATA

One simple click on „TECHNICALDATA“ (right side) and you will get all relevant data for each specific model.



ONLINE HELP

A HELP document is also available online. You will find it in the OMS in the top right corner.

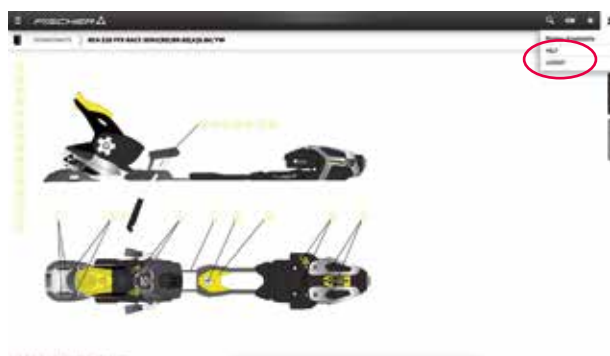

BRAKE LINE UP

Brake Code	Binding	Article No.	Brake Model / Width
BRAKES			
A	RC4 Z 20 FF X RACE SERVICE (RD)	T163033	Power Brake ² Race PRO 17-85 [A]
	RC4 Z 20 FF X RACE SERVICE (RS)	T163035	Power Brake ² Race PRO 95 [A]
	RC4 Z 18 FF X RACE SERVICE	T163036	Power Brake ² Race PRO 110 [A]
	RC4 Z 16 FF X RACE SERVICE (RD)	T163037	Power Brake ² Race PRO 130 [A]
	RC4 Z 17 FREEFLEX	T163038	Power Brake ² Race PRO 150 [A]
	ATTACK 16 W/O BRAKE		
	ATTACK 13 W/O BRAKE		
*use only for competition (X) bindings			
		T163032	Power Brake ² Race PRO 16-85 [A]*
		T163034	Power Brake ² Race PRO 18-85 [A]*
B		T163040	Power Brake ² FR PRO 95 [B]
		T163041	Power Brake ² FR PRO 110 [B]
		T163042	Power Brake ² FR PRO 130 [B]
C	AAAMBITION 10 W/O BRAKE	T163003	Brake Ambition 85 [C]
		T163016	Brake Ambition 95 [C]
		T163004	Brake Ambition 105 [C]
		T163005	Brake Ambition 125 [C]
D	RC4 Z 13 FREEFLEX	T163044	Power Brake ² LD 85 [D]
	RC4 Z 11 FREEFLEX	T163045	Power Brake ² LD 95 [D]
	AAATTACK 13 DEMO W/O BRAKE	T163046	Power Brake ² LD 110 [D]
	XTR 10 PRO	T163047	Power Brake ² LD 130 [D]
	XTR 7 AC PRO	T163048	Power Brake ² LD 150 [D]
E	no brakes in this group available anymore - please use Brakes in group „E or J“		
F	C-LINE Z 13 RACETRACK	T163050	Powerrail Brake ² LD 85 [F]
	RSX 12 POWERRAIL	T163051	Powerrail Brake ² LD 95 [F]
	RC4 Z12 POWERRAIL	T163052	Powerrail Brake ² LD 110 [F]
	AAADRENALIN 13 W/O BRAKE	T163053	Powerrail Brake ² LD 130 [F]
G	RC4 Z11 POWERRAIL	T162943	Powerrail Brake SL 78 [G]
	RS11 POWERRAIL	T162944	Powerrail Brake SL 90 [G]
	RS10 POWERRAIL	T163078	Powerrail Brake SL 100 [G]
	ATTACK 11 DEMO W/O BRAKE	T162985	Powerrail Brake SL 115 [G]
H	RS9 SLR	T162942	SL Brake LR 78 [H]
	W 10 WOMENTRACK	T162949	SL Brake LR 90 [H]
	W 9 WOMENTRACK		
	FJ7 AC JUNIOR RAIL		
I	FJ4 AC SLR	T162966	SX Kid Brake LR 74 [I]
		T162967	SX Kid Brake LR 84 [I]
E	RS10	T163058	SL Brake 78 [E],[J]
J	RS9	T162776	SL Brake 90 [E],[J]
	RC4 Z9 AC	T163067	SL Brake 100 [E],[J]
	FJ7 AC	T163068	SL Brake 115 [E],[J]
K	FJ4 AC	T162964	SX Kid Brake 84 [K]
	XTR 4 AC RENT	T162965	SX Kid Brake 74 [K]
L	ATTACK 11 W/O BRAKE	T163027	SL Brake FS 78 [L]
		T163028	SL Brake FS 90 [L]
		T163029	SL Brake FS 100 [L]
		T163030	SL Brake FS 115 [L]

BRAKE LINE-UP 16I17

- POWER BRAKE² for(A), (B), (D) and (F)
- Standardization of brake group (E) and (J)
- Identification and Naming system
- w/o brake binding models

1. Power Brake² for [A],[B],[D] and [F]

Fischer introduce the new Power Brake² with a better retraction up to 30 mm in comparison to former brakes. The new brake retracts completely to the heel housing. Fischer reduces the amount of brake models in PB segments [A],[B],[D] and [F] due to new width split – 85/95/110/130/150 (from 26 to 19 models). Power Brake² feature a fully compatibility – new brakes match with old bindings and old brakes match with new bindings.

2. STANDARDIZATION OF BRAKE GROUP [E] AND [J]

Fischer made a standardization of the former Brake group [E] and [J]. That means, these 2 groups will be combined in the new group [E],[J] in the first step and after existing stock is delivered the [E] will be deleted completely from our brake line (running change).

Following changes are already done:

- No further production of all brakes in group [E]
- 2 new Brakes in group [J] with width of 100mm (163067) and 115mm (163068) will be added
- 162764 SL Junior Brake 72 [J] was replaced by the 163058 SL Junior Brake 78 [J]

- Adaption of the name:
 - “Junior” will be deleted from the name
 - New group- name will be “SL Brake XX [E],[J]”
- New sticker for [E] or [J] brakes

3. IDENTIFICATION AND NAMING SYSTEM

To make the brake-binding allocation as easy as possible, we are using a color coding system. In addition to the standard product labels of the spare brakes, a color-letter code is affixed on the brake boxes (single and master packaging), as you can see in the pictures below. All bindings packaged without brakes will come with a similar sticker. Matching brakes and bindings has become fast and easy. For a binding with a red sticker [A], the dealer just has to look for a brake with a red sticker [A] in the proper width.



Color-letter-code sticker for spare brakes and bindings



Color-letter-code sticker on packaging of the spare brakes

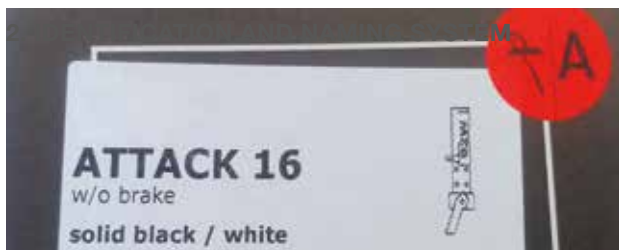

Color-letter-code sticker on all bindings without brakes.

Also the nomenclature of all Fischer brakes is standardized and includes all basic information. These nomenclature consist of a clear name, a number, what defines the maximum ski width at the mounting point and a letter, what specifies the brake cluster

4. W/O BRAKE BINDING MODELS

Fischer is offering some binding models without brakes, (marked “w/o brake”) to avoid brake exchanges later on and to provide suitable brakes for different ski widths. For these models you need to order appropriate brakes separately.

5. PACKAGING

The packaging should help dealers to optimize their storage system. We use 3 different sizes of cardboard boxes for one pair of brakes (20 prs per master box). The boxes are stackable and have additional hang tags. Moreover the labels are visible on two sides on the boxes, which gives the dealer several possibilities to store the brakes, as you can see in the pictures below.



Color-letter-code sticker for spare brakes and bindings)



Packaging with double-side labels and brake code.

DRILL TEMPLATE 92 W & 92 FAT

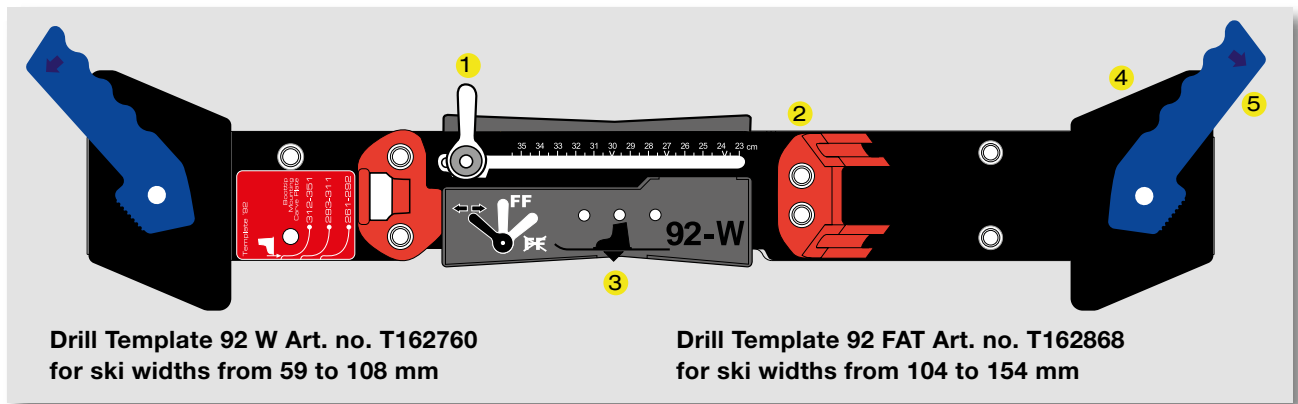

Drill Template 92 W Art. no. T162760
for ski widths from 59 to 108 mm

Drill Template 92 FAT Art. no. T162868
for ski widths from 104 to 154 mm

1. COMPATIBILITY

Presently the drill template 92 W & drill template 92 FAT can be used for:

RC4 Z 20 FF X Race Service	RC4 Z 9
RC4 Z 18 FF X Race Service	FJ 7 AC
RC4 Z 16 FF X Race Service	FJ 7 AC
RC4 Z 17 Freeflex	Attack 16
RC4 Z 13 Freeflex	Attack 13
RC4 Z 11 Freeflex	Attack 11
RS 10	

All Fischer adult bindings come with screws with a penetration depth of 8 mm for skis, group G1 & G2. The junior bindings are delivered with screws with a penetration depth of 6 mm. For mounting junior bindings on plates or on skis, group G1 & G2, replace them by longer screws.

Drill template 92 W can be used for ski widths from 59 mm to 108 mm, whereas the Drill template 92 FAT fits ski widths from 104 mm to 154 mm. For other skis use the template adapter set (Art. No. T162569). With this adapter set, you can mount skis from 45 mm to 132 mm with the standard drill template 92 W, as well as skis from 90 mm to 178 mm with Drill Template 92 FAT.

NOTE: Fischer offers different types of brakes. Refer to the brake overview for brake and binding compatibility.

The Description of the brakes always includes a number like 72, 78, 90, 97, 115, and so on **This number stands for the maximum ski width in the brake area and not in the ski center!!!**

2. ADJUSTING THE DRILL TEMPLATE

There are two different mounting procedures for template 92. One for FREEFLEX PRO and one for TWO-PIECE bin-

dings. To adjust the template unlock the locking lever (1) by rotating it counter-clockwise to the far left position.

FREEFLEX PRO

NOTE: Due to the center piece these bindings are limited to ski boots with sole lengths from 257 to 372 mm. Place the ski boot in the template and push the template together until the stops (2) come against the ski boot sole. Take the boot out of the template. Position the locking lever (1) in the mid position, then open or close the template to the nearest centimeter mark.

FOR TWO-PIECE AND AAATTACK BINDINGS

Place the ski boot in the template and push the template together until the stops (2) come against the ski boot sole. Lock the lever to the far right position to prevent length change, and then take the boot out of the template. For AAATTACK 13 LT adjust the template to 27 cm for short mounting position (boot-sole-length 260-320 mm) or to 31cm for long mounting position (boot-sole-length 300-360 mm).

3. POSITIONING OF THE DRILL TEMPLATE

Open the clamping jaws (4) of the template by rotating the clamping handles (5) and then place template correctly on the ski, with the boot midsole indicator (3) aligned with the mounting mark on the ski. Be sure the template is evenly seated against the ski's top surface. Release clamping handles to attach the template to the ski. Check the boot midsole mark with template mark. If they are not the same use the boot midsole mark to align the template with the ski mounting mark.

NOTE: Keep in mind that some ski manufacturers do not use the center of boot sole location method. Always follow their instructions.

4. DRILLING THE HOLES

If not otherwise specified by the ski manufacturer, use a 4.1 Ø x 9.0mm drill bit. Use a 4.1 Ø x 7.0 mm drill bit for skis, group G3 & G4.

Drill the holes using the appropriate drill bit. If required by the ski manufacturer, tap the holes. After drilling place a drop of FISCHER glue in each hole. It lubricates the screws and seals the holes.

5. MOUNTING

5.1 FOR FREEFLEX X/PRO

Place the pre-assembled heel over the prepared holes and tighten the screws in a cross pattern.



Then attach the AFD to the toe and check if the AFD has snapped in, in its specific position.



Then you have to place the pre-assembled toe over the holes.



ATTENTION: First you have to tighten the screw in the center – the number has to correspond to the centimetre mark from the template. To fix it you have to hold the bands together and tighten the screw carefully.

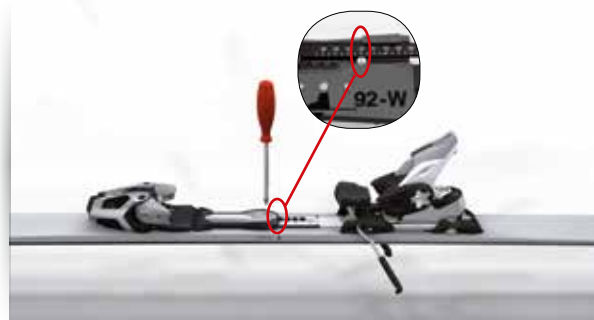

After this align the toe over the holes and fasten the screws in a cross pattern.



5.1.1 SOLE HEIGHT ADJUSTMENT - FREEFLEX X

For proper function of the Freeflex X binding the height of the Race AFD must be adjusted to the height of the boot sole. Fischer recommends using the "Fischer boot height adjustment tester" (Art.No. T162983) to get the ideal distance of 0.5 mm between boot and AFD. Use Freeflex X bindings only with Alpine boots.

Turning the adjustment screw at the toe moves the Wings up or down.

Place the tester on the AFD and enter the boot in the binding. Lift the tip of the boot to take out the play of the toe.



Adjust the AFD with the screw on the top so that the tester is still moveable but with a slight resistance. In this case, you reached a gap of 0.5 mm between AFD and the boot.

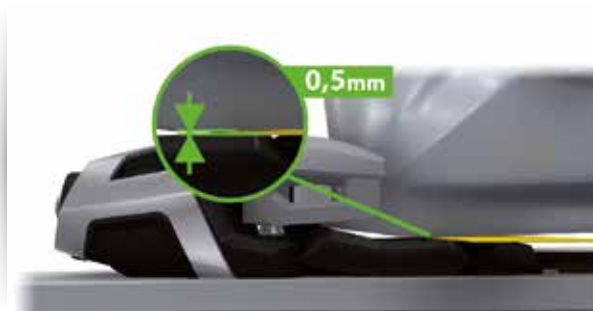

If the tester is not moveable, the gap is smaller than 0,5 mm, if you feel no resistance the gap is more than 0.5 mm. In both cases you need to re-adjust the AFD.

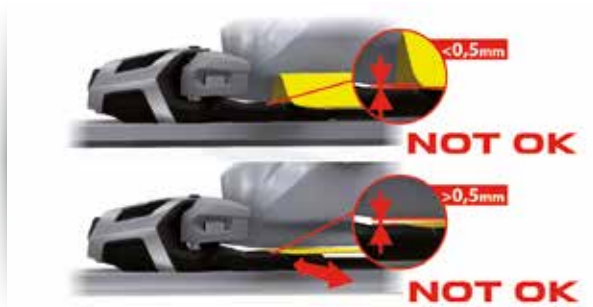

5.2 FOR TWO-PIECE BINDINGS

Hook the brake into heel housing and place the binding over the predrilled holes and tighten the screws in a cross pattern.



5.3 AAATAACK 16, 13 AND 11 BINDINGS

For mounting AAATAACK 16, 13 or 11 bindings hook the brake into heel housing and place the heel unit over the predrilled holes and tighten ten screws in a cross pattern. For toe unit, place the mounting part over the front 2 predrilled hole and tighten the screws. Now slide the toe unit from rear over the mounting part and fasten the screws.



5.3.1 SOLE HEIGHT ADJUSTMENT

For proper function the height of the AFD must be adjusted to the height of the boot sole. FISCHER recommends to use the "AAA BOOT HEIGHT ADJUSTMENT TESTER" (Art. No. T162983) to get the ideal distance of 0.5 mm between boot and AFD.

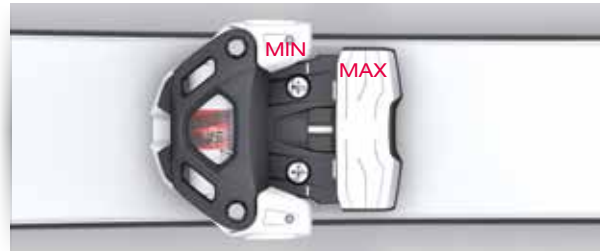

The Attack 13 AT provides full AT adjustability for alpine, walking and touring boots. Please use the A (Alpine), W (Walk) and T (Touring) markings for rough adjustment.



Use AAATAACK bindings only with Alpine boots (TYPE A). Turning the adjustment screw at the toe moves the AFD up or down. Place the tester on the AFD and enter the boot in the binding. Lift the tip of the boot to take out the play of the toe. Adjust the AFD with the screw in the front so that the tester is still moveable but with a slight resistance. In this case, you reached a gap of 0.5 mm between AFD and the boot.



Place the ski boot in the open binding and rest the boot heel on the brake pedal. Lift the length adjustment lock with a screwdriver and slide the heel until the heel cup just touches the boot. Lock the length adjustment by pushing it down. Latch the boot in the binding and check forward pressure again. The toe pincers should not be pressed open and the indicating pointer should rest within the scribed area.

If the tester is not moveable, the gap is smaller than 0.5 mm, if you feel no resistance the gap is more than 0.5 mm. In both cases you need to re-adjust the AFD.



7. JUNIOR BINDINGS

7.1 AFS JUNIOR ON DIN 7.5 AC MODELS

The SX Junior Line is suitable for both adult (type A) and children (type C) boots: the innovative mechanical Anti Friction Slider (AFS) automatically adjusts to the boot sole height, compensating A/C standards as well as height differences due to icing up, dirt or boot wear.



6. FORWARD PRESSURE

Make sure that the boot meets international standards and is not damaged. Place the boot in the binding and close it. The indicating pointer should rest within the scribed area if not, you have to adjust the forward pressure. **DON'T OPEN THE LENGTH ADJUSTMENT LOCK AS LONG AS A SKI BOOT IS FIXED IN THE BINDING.**

If you want to increase the stability of your junior binding in combination with children (type C) boots, e.g. for junior racing, you can replace the standard AFS with a vertically blocked AFS (Art. No. T162962), which is for children (type C) boots ONLY. All you have to do is to separate the standard slider from the base plate.

Afterwards you can simply click in the spare slider.



7.2 MOUNTING OF JUNIOR BINDINGS ON PLATES AND ON SKIS, GROUP G1 & G2

For mounting junior bindings on plates or on skis, group G1 & G2, replace the pre-mounted screws by 8 mm penetration depth screws. Only with these screws the right pullout strength is guaranteed.

8. ADJUSTING THE RELEASE VALUES

The release values of the toe and heel should be determined by height and body weight (ISO/ASTM) method. Set the binding accordingly with the adjustment screws at heel- and toe unit - therefore use a manual screwdriver. We recommend the use of a calibrated testing device and that you keep a written record of whether the system passes or fails (requirement in the US).

NOTE: Release/retention settings above a release moment of 100 NM at the toe and 400 NM at the heel are higher than the international standards recommend and are used solely at the skier's own risk!

9. FUNCTION CHECK

ENTRY/EXIT: Check to make sure that the boot does not catch on the heel hold down lug.

BRAKE: press the brake pedal (1) down by hand. The brake arms (2) must automatically return to the braking position when the pedal is released.

LATERAL ELASTICITY OF THE TOE

Press the boot laterally outward. The binding must re-center the boot easily and quickly from a 15 mm lateral displacement (junior bindings – 10 mm).

10. FINAL CHECK

- Has the proper mounting point been selected?
- Functional brake test passed?
- Have all screws been fastened tightly?
- Has the forward pressure been properly set?
- Are the release values of the toe and heel properly determined and set?
- Is the instruction for use booklet ready to be handed over to the consumer?

DRILL TEMPLATE AAAMBITION

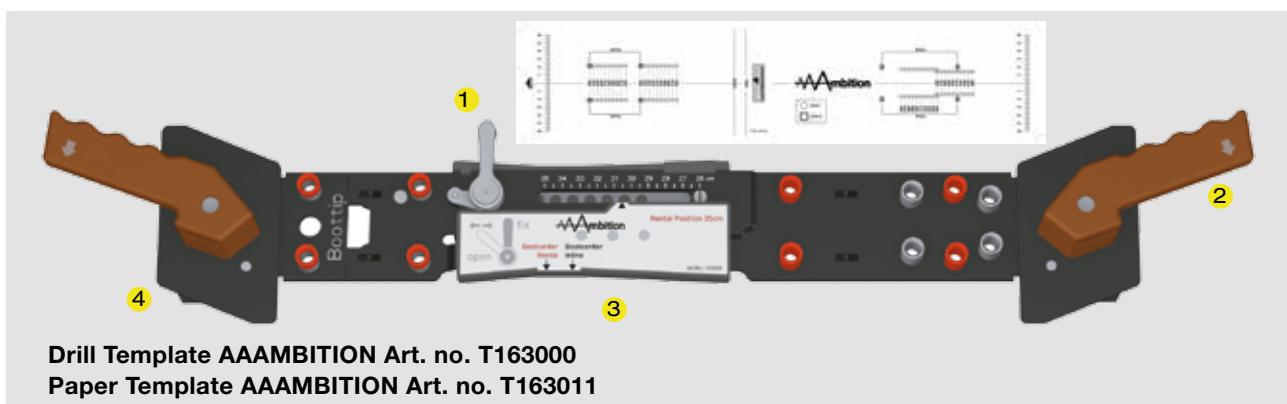

1. COMPATIBILITY

Presently the drill template AAAMBITION can be used for:

AAAMBITION 10

All AAAMBITION bindings come with 8 mm penetration screws and can be used with skis of groups G1 & G2. Drill template AAAMBITION can be used for ski widths from 75 to 125 mm. For other skis use the template adapter set (Art. No. T162569). With this adapter set, skis from 61 to 149 mm can be mounted. Alternatively the usage of the attached paper template is possible.

NOTE: FISCHER offers different types of brakes. Refer to the brake overview for brake and binding compatibility.

The description of the brakes always includes a number like 88, 97, 115, 130. This number stands for the maximum ski width in the brake area and not in the ski center!!!

2. POSITIONING OF THE TEMPLATE

There are two ways to mount AAAMBITION bindings. Either with the solid jig (Art. No. T163000) or with the paper template (Art. No. T163011), which is included in the packaging of each binding. We will show both procedures. First of all, make sure that the boot is satisfying the international standards and has no functional damage. Determine the boot sole length with the FISCHER rental caliper (Art. No. T162617).



NOTE: Keep in mind that some ski manufacturers do not use the center of boot sole location method. Always follow their instructions.

2.1. DRILL TEMPLATE

Adjust the boot sole length on the template - open it by pulling the locking lever (1) to the left position. Slide the template to the right length position and push the locking lever (1) to middle position. Slide the template to closest centimeter mark, until it snaps into position. Place the template on the ski and center the jig. Therefore open the clamping jaws (2) by rotating the clamping handles (3) and then place the template on the ski.

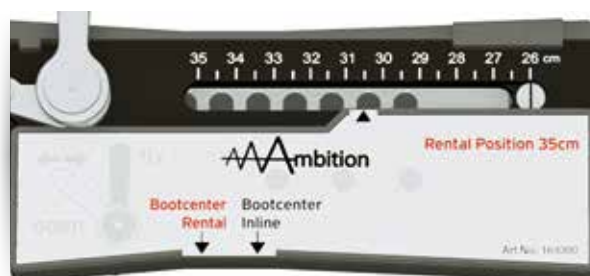

Therefore select right midsole indicator on the template (Black for RETAIL and Red for RENTAL version), align the indicator with the midsole mounting mark on the ski. Release the handles and ensure that the template is evenly seated against the ski's top surface. Select the right holes! The front holes are identical for both versions (Retail and Rental - red-silver bushings).

You just have to select the right bushings for the rear holes:

Version	Colour of bushing
AAAMBITION Retail	silver
AAAMBITION Rental	red

2.2. PAPER TEMPLATE

Follow the same procedure with the plastic foil template - place it on the ski, align the correct boot mid sole mark with the ski mounting mark. Fix it with a sticky tape and ensure that the template is centered and evenly seated against the ski's top surface.

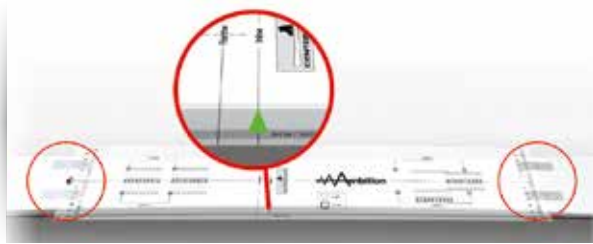

After that you can mark the correct positions with a punch for front and rear position. For Retail Version use the circle-indicator ○ and mark the closest centimeter position. For Rental version use the quad-indicators □.



3. DRILLING THE HOLES

If not otherwise specified by the ski manufacturer, use a 4.1 Ø x 9 mm drill bit for the toe and the heel track (8 holes) if required by the ski manufacturer, tap the holes. After drilling, place a drop of FISCHER glue into the holes. It lubricates the screws and seals the holes.



4. MOUNTING

Just start with mounting the Heel unit of the binding depending on the version. The mounting of the toe unit is the same in both versions.

4.1.1 RETAIL VERSION – HEEL UNIT

Place the heel unit over the rear holes and fasten all screws in a cross pattern and continue at 4.2.



4.1.2 RENTAL VERSION – HEEL UNIT

Start with placing the Demo Track over the holes and fasten all screws in a cross pattern. Use the included screws from the binding.



Stick in the fixing screw in the cavity on the bottom side of the heel unit and slide the unit to the closest mounting position on demo track and fix it with the screw. and continue at 4.2.



Place the toe unit assembly over the two front holes and fasten the screws.



Open the climbing aid and tighten the other two screws of the toe unit.

4.2 MOUNTING OF THE TOE UNIT

If you are mounting the RENTAL version, the damper has to be changed (white damper out and black one in).



From now on the mounting is the same in both version (RETAIL and RENTAL).

Start with the Adjustment of the telescopic tube to the closest mounting position and fix it with the screw.

ATTENTION!!!! AAAmbition binding are consigned without brakes. Please choose the fitting brake width for your ski and mount it on the binding or use to ride and hike the appropriate powder straps. It is required to use one of them (referred to ISO 11088)!!



Art. No.	Spare parts
T163003	Brake AAAMBITION 85 (C) (1 pair)
T163016	Brake AAAMBITION 95 (C) (1 pair)
T163004	Brake AAAMBITION 105 (C) (1 pair)
T163005	Brake AAAMBITION 125 (C) (1 pair)
T162981	Powder Strap AAA-Series (1 pair)

Close the ascender lock and slide the binding into the closed position in all versions.

4.3 MOUNTING OF THE BRAKES

Demount the heel base plate – therefore remove both screws completely. Pop out the plate with a flat screwdriver.



Take the AAAMBITION brake, press it together and clap the brake pedal to a horizontal position. First click right then left side into place.



Check the right position of the brake.

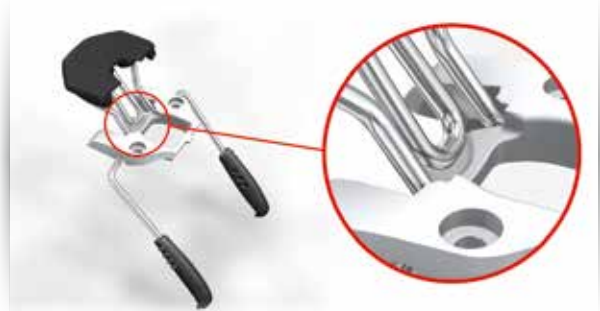

Place the heel base plate with the brake to its position on the heel unit, push the plate to lock on binding. Fix the plate with the two screws. Ready!!



4.4 SOLE HEIGHT ADJUSTMENT

The AAAmbition is designed to accommodate both type of boots - ALPINE SKI BOOTS (according to DIN/ISO 5355) and TOURING BOOTS (according to DIN/ISO 9523). For proper function the height of the toe unit must be adjusted to the height of the boot sole. FISCHER recommends to use the "AAA BOOT HEIGHT ADJUSTMENT TESTER" (Art. No. T162983) to get the ideal distance of 0.5 mm between boot and AFS. Turning the adjustment screw at the toe moves the unit up or down. Place the tester on the AFS and enter the boot in the binding. Lift the tip of the boot to take out the play of the toe.



Adjust the AFS with the screw in the front so that the tester is still moveable but with a slight resistance. In this case, you reached a gap of 0.5 mm between AFS and the boot. If the tester is not moveable, the gap is smaller than 0,5 mm, if you feel no resistance the gap is more than 0.5 mm. In both cases you need to re-adjust the AFS.



5. FORWARD PRESSURE

Check the forward pressure, by placing a boot into the binding. If you have followed all mounting steps correctly, the indicator and the heel housing should be on a flat surface.

WHILE SKI BOOT IS IN THE BINDING ADJUSTMENT IS FORBIDDEN!

If you have too much or not enough forward pressure, check the settings and if necessary re-adjust the heel.



6. ADJUSTMENT OF THE RELEASE VALUES

The release values at toe and heel should be determined by height and body weight (ISO/ASTM) method. Set the binding accordingly with the adjustment screws. We recommend the use of a calibrated testing device and that you keep a written record of whether the system passes or fails (requirement in the US).

NOTE: Release/ Retention settings above a release moment of 100 NM at the toe and 400 NM at the heel are higher than the international standards recommend and are used solely at the skier's own risk!

7. FUNCTION CHECK

Check the function of the heel. Make sure that the boot does not catch on the heel during entry and exit. Check the brake function by pressing down the brake pedal (1) by hand. The brake arms (2) must open to the braking position when the brake pedal is released. Check the elasticity and retention of the toe by pushing the boot inward and outward.



The binding must recenter the boot easily and quickly from a 15 mm lateral displacement.

8. ADDITIONAL EQUIPMENT AND SPARE PARTS FOR AAAMBITION:

8.1 AAAMBITION CRAMPONS

FISCHER is offering additional crampons for AAAMBITION Bindings. Use the crampons at icy and hard snow conditions to provide safe climbing and a secure stand in any situation. Be attended to use the right width - 90 mm (Art.No. T163006), 105 mm (Art.No. T163007) or 120 mm (Art.No. T163008).

MOUNTING: Open the climbing aid and swing open the binding. Take the crampon and slide it to the fixing- position on the bottom of the telescopic tube.



Consider the right position. Lock the crampon with the lever- ready!

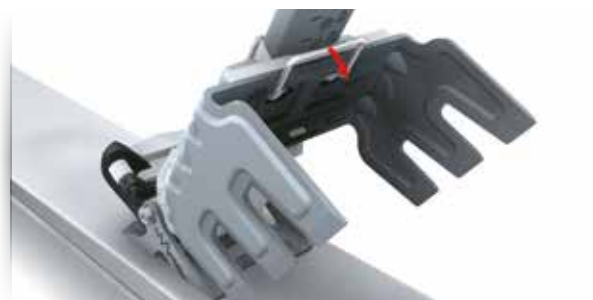

8.2 AAA-SERIES POWDER STRAP

Instead of brakes it is also possible to use the AAA-Series powder strap for riding and hiking. At AAAMBITION bindings it is required to use either brakes or powder strap! To fix the strap on your binding take the hanger from the strap and fix it on the heel lever.



Fix the strap with the Velcro fastener on your leg and use the carabiner to connect strap and hanger again.

9. FINAL CHECK

- Has the proper mounting point been selected?
- Functional brake test passed?
- Have all screws been fastened tightly?
- Has the forward pressure been properly set?
- Are the release values of the toe and heel properly determined and set?
- Is the instruction for use booklet ready to be handed over to the consumer?

DRILL TEMPLATE AADRENALIN

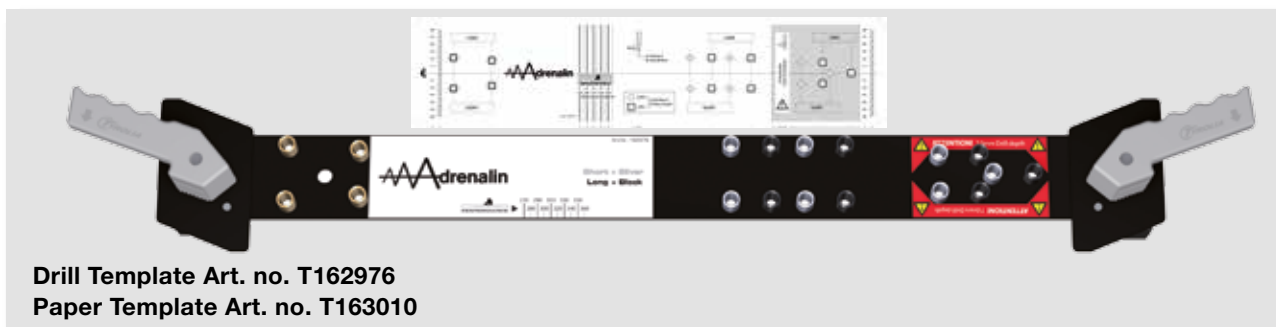

Drill Template Art. no. T162976
Paper Template Art. no. T163010

1. COMPATIBILITY

Presently the drill template AADRENALIN can be used for:

- AAADRENALIN 16 long AAADRENALIN 13 long
- AAADRENALIN 16 short AAADRENALIN 13 short

All AAADRENALIN bindings come with 8mm penetration screws (except the screws for the locking mechanism, which have only 6 mm penetration) and can be used with skis of groups G1 & G2.

Drill template AADRENALIN can be used for ski widths from 75 to 125 mm. For other skis use the template adapter set (art. no. T162569). With this adapter set skis from 61 to 149 mm can be mounted.

NOTE: Fischer offers different types of brakes. The Description of the brakes always includes a number like 88, 97, 115, 130. This number stands for the maximum ski width in the brake area and not in the ski center!!!

2. POSITIONING OF THE TEMPLATE

There are two ways to mount AAADRENALIN bindings. Either with the solid jig (art. no. T162976) or with the paper template, which is included in the packaging of each binding.

We will show both procedures. First of all make sure that the boot is satisfying the international standards and has no functional damage. Determine the boot sole length with the Fischer rental caliper (art. no. T162 617).



NOTE: Keep in mind that some ski manufacturers do not use the center of boot sole location method. Always follow the ski manufacturer's instructions.

2.1. DRILL TEMPLATE

Open the clamping jaws (2) by rotating the clamping handles (1) and then place the template on the ski. Align the boot midsole indicator (3) for the appropriate boot sole



length with the midsole mounting mark on the ski. Release the handles and ensure that the template is evenly seated against the ski's top surface.

The front holes are identical for both versions (gold bushings). You just have to select the right bushings for the rear holes: AAADRENALIN short 270-330 mm (silver), AAADRENALIN long 300-360 mm (black).

2.2. PAPER TEMPLATE

Align the boot midsole indicator for the appropriate boot sole length with the midsole mounting mark on the ski. Fix it with a sticky tape and ensure that the template is centered and evenly seated against the ski's top surface.

After that you can mark the correct indicators with a punch.

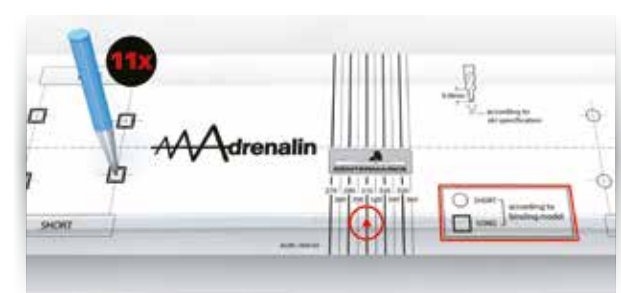

The front holes are identical for both versions. You just have to select the right indicator for the rear holes: AAADRENALIN Short 270-330 mm (Symbol ○), AAADRENALIN Long 300-360 mm (Symbol □).

NOTE: Keep in mind that some ski manufacturers do not use the center of boot sole location method. Always follow the ski manufacturer's instructions.

3. DRILLING THE HOLES

If not otherwise specified by the ski manufacturer use a 4.1 Ø x 9mm drill bit for the holes for the toe and the heel track and a 4.1 Ø x 7mm drill bit for the holes for the locking mechanism. If required by the ski manufacturer, tap the holes.



After drilling place a drop of Fischer glue into the holes. It lubricates the screws and seals the holes.

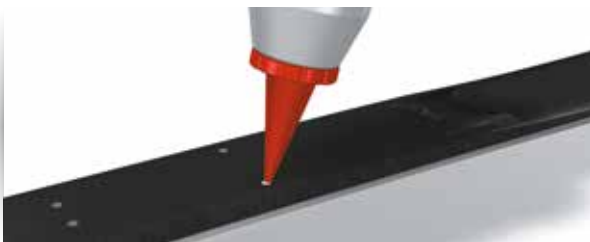

4. MOUNTING

Place the heel track assembly over the holes and fasten all screws in a cross pattern.

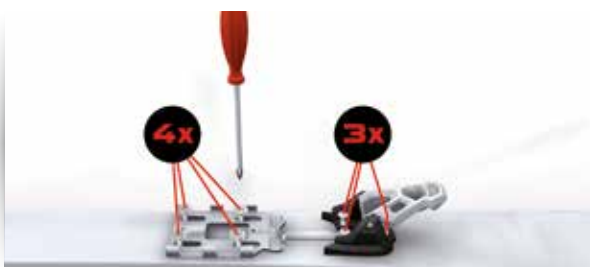

Then you can place the toe assembly over the holes and fasten the two front screws lightly.



After that you have to close the platform with the ascender lock and then tighten fast the front screws.



Open the lock again and tighten the other two screws of the toe piece.



Now you can mount the heel. Therefore hook the brake into the heel housing, slide the heel on the platform from the back and lock it at the appropriate boot sole marking.



After that you can close the ascender lock and you are ready for the final adjustments.





5. SOLE HEIGHT ADJUSTMENT

The AAADRENALIN is designed to accommodate both type of boots - ALPINE SKI BOOTS (according to DIN/ISO 5355) and TOURING BOOTS (according to DIN/ISO 9523). For proper function the height of the AFS must be adjusted to the height of the boot sole. Fischer recommends to use the "AAA boot height adjustment tester" (art. no. T162983) to get the ideal distance of 0.5 mm between boot and AFS. Turning the adjustment screw at the toe moves the AFS up or down.

Place the tester (Art. No. T162983) on the AFS and enter the boot in the binding. Lift the tip of the boot to take out the play of the toe.



Adjust the AFS with the screw in the front so that the tester is still moveable but with a slight resistance. In this case, you reached a gap of 0.5 mm between AFS and the boot. If the tester is not moveable, the gap is smaller than 0,5 mm, if you feel no resistance the gap is more than 0.5 mm. In both cases you need to re-adjust the AFS.

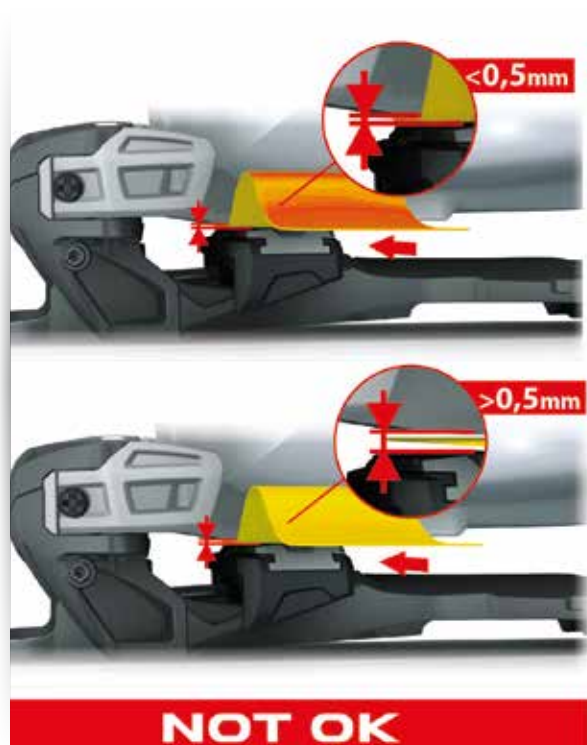

6. FORWARD PRESSURE

Check the forward pressure, by placing a boot into the binding. If you have followed all mounting steps correctly, the indicator should rest in the marked area- and you are ready to go.



If you have too much or not enough forward pressure, check the settings and if necessary re-adjust the heel. Then close the lever and check the forward pressure again. Now it should be okay.

7. ADJUSTMENT OF THE RELEASE VALUES

The release values at toe and heel should be determined by height and body weight (ISO/ASTM) method. Set the binding accordingly with the adjustment screws. We recommend the use of a calibrated testing device and that

you keep a written record of whether the system passes or fails (requirement in the US).

NOTE: Release/ Retention settings above a release moment of 100 NM at the toe and 400 NM at the heel are higher than the international standards recommend and are used solely at the skier's own risk!



8. FUNCTION CHECK

Check the function of the heel. Make sure that the boot does not catch on the heel during entry and exit. Check the brake function by pressing down the brake pedal (1) by hand. The brake arms (2) must open to the braking position when the brake pedal is released. Check the elasticity and retention of the toe by pushing the boot inward and outward. The binding must recenter the boot easily and quickly from a 15 mm lateral displacement.

9. ADDITIONAL EQUIPMENT AND SPARE PARTS FOR AAADRENALIN:

9.1 AAADRENALIN CRAMPONS

FISCHER is offering additional crampons for AAADRENALIN Bindings. Use the crampons at icy and hard snow conditions to provide safe climbing and a secure stand in any situation. Be attended to use the right width - 90 mm (Art.No. T162977), 105 mm (Art.No. T162978) or 120 mm (Art.No. T162979).



MOUNTING: Open the climbing aid and swing open the binding. Take the crampon and slide it to the fixing-position on the bottom of the hiking platform. Consider the right position.

Lock the crampon with the lever- ready! To demount just unlock the crampon with the lever and take off the crampon from the platform.

9.2 AAA-SERIES POWDER STRAP (Art.No. T162981)

Instead of brakes it is also possible to use the AAA-Series powder strap for riding and hiking. At AAADRENALIN bin-



ding it is required to use either brakes or powder strap! To fix the strap on your binding take the hanger from the strap and fix it on the heel lever. Fix the strap with the Velcro fastener on your leg and use the carabiner to connect strap and hanger again.

9.3 SPARE PARTS FOR AAADRENALIN Changing AFS Metal Pro Art. No. T162984

Slide the AFS by turning the adjustment screw to highest



position. Take off the old AFS. Open the ascender lock and bring the new spare part in position. Attend that AFS is positioned on the two side rails and the guide screw of the binding matches the screw -nut at AFS. Therefore press the screw from the bottom up and slide the AFS to rails at once. Make a readjustment of your sole height as described before.



Changing the climbing aid set Art. No.T162892

The climbing aid includes 1 wrench, 2 screws, 2 fixing parts and 2 climbing levers.

First open the ascender lock and slide the heel housing from the platform.

Remove the fixing screw with the added wrench on the top of the platform and furthermore the fixing part and the climbing lever from the bottom.

- Is the forward pressure properly adjusted?
- Are the release values of the toe and heel properly determined and set?
- Is the instruction for use booklet ready to be handed over to the consumer?



Put the binding to a straight position. Insert and click the new parts into position – use the 13° climbing position.



Fasten the screw and check the all 3 climbing positions. Slide the heel housing with the brake from the back and lock it at the appropriate boot sole marking.

10. FINAL CHECK

- Is the proper mounting point selected?
- Functional brake test passed?
- Are all screws fastened tightly?

DRILL TEMPLATE AAATTACK DEMO

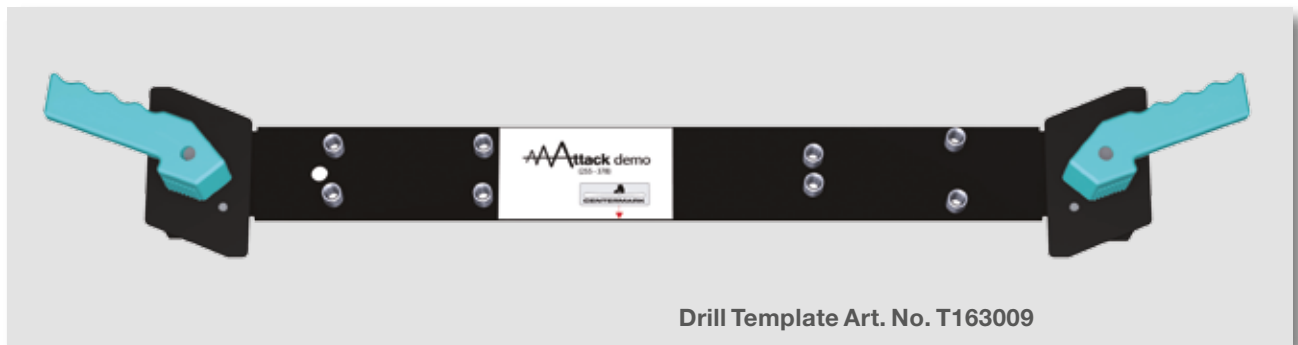

Drill Template Art. No. T163009

1. COMPATIBILITY

Presently the drill template AAATTACK Demo can be used for:

- AAATTACK 13 DEMO
- AAATTACK 11 DEMO

All AAAttack Demo bindings come with 8 mm penetration screws and can be used with skis of groups G1 & G2.

For mounting AAAttack Demo bindings on G3 & G4 skis and on Fischer skis with LIBRA, Women's architecture the premounted screws have to be changed. Therefore use the spare part "Screw Set AAAttack Demo – G3 & G4 (6 mm)" A.No. T163 024 or "Screw Set Attack 11 Demo – G3 & G4 (6 mm)" (Art.No. T163073).

Drill template AAAttack Demo can be used for ski widths from 75 to 125 mm. For other ski widths please use the template adapter set (A.No. T162 569). With this adapter set skis from 61 to 149 mm can be mounted.

NOTE: Fischer offers different types of brakes. Refer to the brake overview on page 33 for brake and binding compatibility.

The description of the brakes always includes a number and a color-letter code. This number stands for the maximum ski width in the brake area and not in the ski center! The color letter code defines the brake segment.

For AAATTACK Demo bindings all brakes of segment [D] are compatible for use!!

2. POSITIONING OF THE TEMPLATE

There are two ways to mount AAAttack Demo bindings. Either with the solid jig (A.No.T163 009) or with the paper template (this is included in the packaging of each binding and also available as a spare part A.No. T163 015). We will show both procedures.

NOTE: Keep in mind that some ski manufacturers do not use the center of boot sole location method. Always follow the ski manufacturer's instructions.



2.1. DRILL TEMPLATE

Open the clamping jaws by rotating the clamping handles and then place the template on the ski. Align the boot midsole indicator with the midsole mounting mark on the ski. Release the handles and ensure that the template is evenly seated against the ski's top surface.

2.2. PAPER TEMPLATE

Align the boot midsole indicator with the midsole mounting mark on the ski. Fix it with a sticky tape and ensure that the template is centered and evenly seated against the ski's top surface. After that you can mark the indicators (8x) with a punch and remove the paper template from the ski surface.

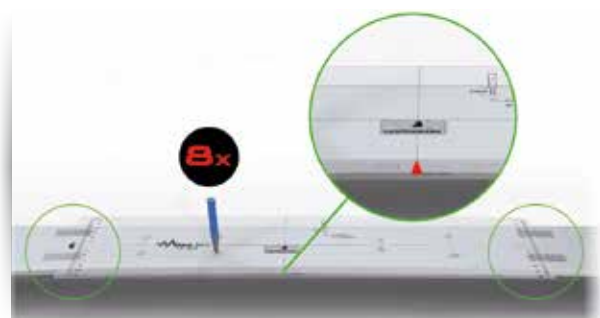

3. DRILLING THE HOLES

If not otherwise specified by the ski manufacturer use a 4.1 Ø x 9 mm drill bit for all holes (8x) for the toe and the heel track. If you are mounting AAAttack Demo bindings on G3 & G4 or on Fischer skis with LIBRA Women's ski architecture please use a 3.5 Ø x 7 mm drill bit and use the shorter screws for mounting (spare part "Screw Set AAAttack Demo G3 & G4" A.No. T163 024).



After drilling place a drop of Fischer glue into the holes. It lubricates the screws and seals the holes.

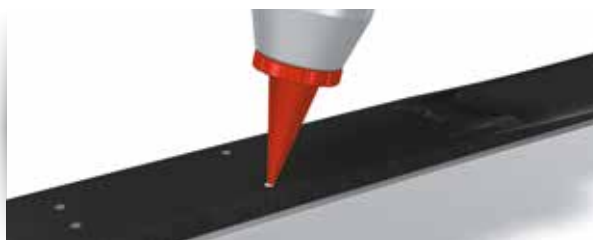

4. MOUNTING

First of all, make sure that the boot is satisfying the international standards and has no functional damage. Determine the boot sole length with the Fischer rental caliper (A.No. T162 617). Go on with placing the toe track over the holes and fasten all screws in a cross pattern. **Don't forget to add the separate base plate at AAATTACK 11 DEMO other- wise you will damage the ski!!**



Open the one-touch lever and slide the toe unit from the front on the track and lock it at the appropriate boot sole marking.

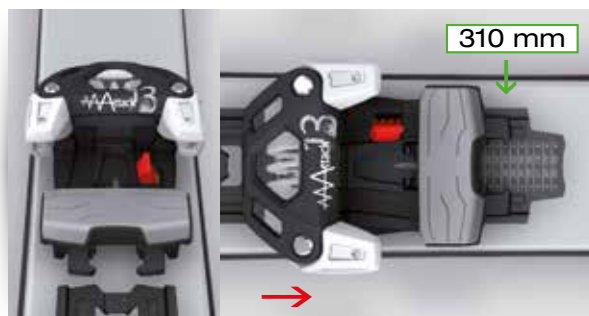

Now you can mount the heel unit. The mounting process is a bit different between AAATTACK 13 DEMO and AAATTACK 11 DEMO.

AAATTACK 13 DEMO

Don't forget to add the separate white base plate otherwise you will damage the ski!!

Hook the brake into the heel track and place the base plate and the heel track over the holes and fasten all 4 screws in a cross pattern.



Now open the one touch lever and slide the heel unit from the back to the track and lock it at the appropriate boot sole marking.

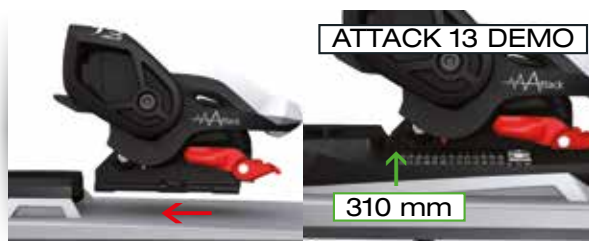

AAATTACK 11 DEMO

Place the heel track over the holes and fasten all screws in a cross pattern.



Now hook the brake into the heel, open the one touch lever, slide the heel unit from the back to the track and lock it at the appropriate boot sole marking.

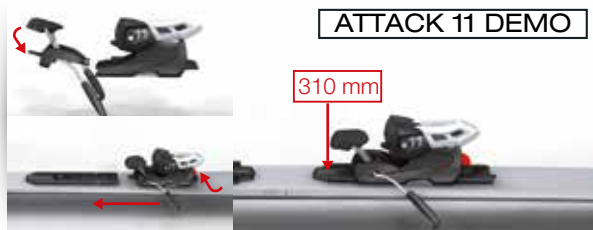

5. SOLE HEIGHT ADJUSTMENT

For proper function the height of the AFS must be adjusted to the height of the boot sole. Fischer recommends using the “AAA BOOT HEIGHT ADJUSTMENT TESTER” (A.No. T162 983) to get the ideal distance of 0.5mm between boot and AFS. Use AAAAttack Demo bindings only with Alpine boots (TYPE A).

Turning the adjustment screw at the toe moves the AFS up or down. Place the tester on the AFS and enter the boot in the binding. Lift the tip of the boot to take out the play of the toe. Adjust the AFS with the screw in the front so that the tester is still moveable but with a slight resistance.



In this case, you reach a gap of 0.5mm between AFS and the boot.

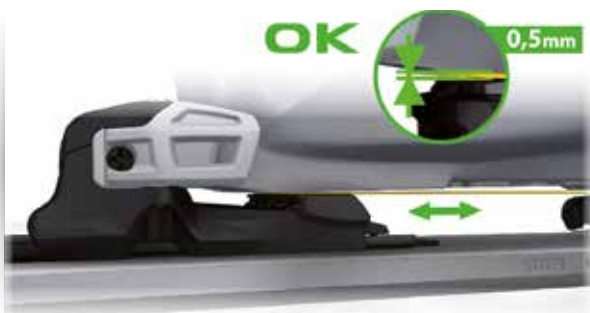

If the tester is not moveable, the gap is smaller than 0,5 mm, if you feel no resistance the gap is more than 0.5 mm. In both cases you need to re-adjust the AFS.



6. FORWARD PRESSURE

Check the forward pressure, by placing a boot into the binding. If you have followed all mounting steps correctly, the indicator should rest in the marked area– and you are ready to go.



If you have too much or not enough forward pressure, check the settings and if necessary re-adjust the heel. Then close the lever and check the forward pressure again. Now it should be okay.

7. ADJUSTMENT OF THE RELEASE VALUES

The release values at toe and heel should be determined

by height and body weight (ISO/ASTM) method. Set the binding accordingly with the adjustment screws. We recommend the use of a calibrated testing device and that you keep a written record of whether the system passes or fails (requirement in the US).

NOTE: Release/ Retention settings above a release moment of 100 NM at the toe and 400 NM at the heel are higher than the international standards recommend and are used solely at the skier's own risk!

8. FUNCTION CHECK

Check the function of the heel. Make sure that the boot does not catch on the heel during entry and exit. Check the brake function by pressing down the brake pedal (1) by hand. The brake arms (2) must open to the braking position when the brake pedal is released. Check the elasticity and retention of the toe by pushing the boot inward and outward.



The binding must recenter the boot easily and quickly from a 15 mm lateral displacement.

9. FINAL CHECK

- Was the proper mounting point selected?
- Did it pass the functional brake test?
- Are all screws fastened tightly?
- Is the forward pressure properly adjusted?
- Are the release values of the toe and heel properly determined and set?
- Is the instruction for use booklet ready to be handed over to the consumer?

DRILL TEMPLATE 94 W

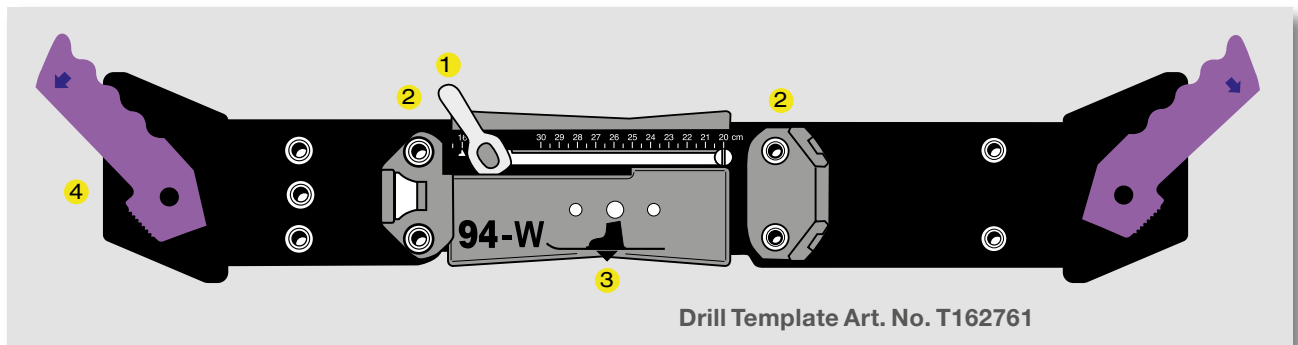

1. COMPATIBILITY

Presently the drill template 94 W is valid for:
FJ 4 AC

Drill template 94 W can be used for ski widths from 59 mm to 108 mm. For other skis use the template adapter set (Art. No. T162569).

The FJ 4 AC binding comes with 6 mm penetration depth screws and thus could be used for skis, group G3 & G4. The standard brake, the SX KID BRAKE 74 (Art. No. T162983), can be used for skis up to 74 mm, for wider skis use the SX KID BRAKE wide 84 (Art. No. T162964), which is for skis from 74 mm to 84 mm.

NOTE: FISCHER offers different types of brakes. Refer to the brake overview for brake and binding compatibility. The description of the brakes always includes a number like 74 or 84. This number stands for the maximum ski width in the brake area and not in the ski center!!!!

2. ADJUSTING THE DRILL TEMPLATE

Unlock the locking lever (1) by rotating it counter-clockwise. Place the template on the ski. Place the ski boot in the template. Push the template together until the stops are against the sole (2). Lock the lever (1) to prevent length change and take the boot out of the template.

3. POSITIONING OF THE DRILL TEMPLATE

Align the boot midsole indicator (3) with the midsole mounting mark on the ski. Be sure the template is evenly seated against the ski's top surface. Release clamping handles to attach the template to the ski. Check the boot midsole mark with template mark. If they are not the same use the boot midsole mark to align the template with the ski mounting mark.

NOTE: Some ski manufacturers do not use the center of

boot sole location method. Always follow the ski manufacturer's instructions.

4. DRILLING THE HOLES

If not otherwise specified by the ski manufacturer, use a 4.1 Ø x 7.0 mm drill bit, which is the right bit for skis, group G3 & G4. Drill the holes using an appropriate FISCHER drill. If required by the ski manufacturer, tap the holes. Place a drop of FISCHER glue into the holes. It lubricates the screws and seals the ski.

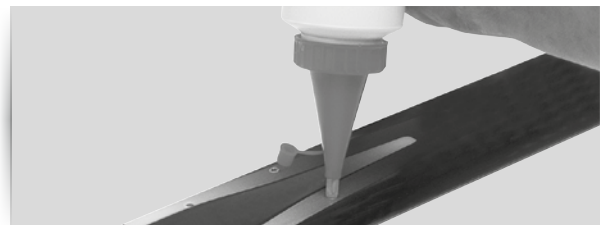

5. MOUNTING

Place the toe unit over the holes and fasten the screws in an X-pattern. Then do the same for the heel.

6. FORWARD PRESSURE

Place the boot in the binding and close it. The indicating pointer should rest within the scribed area (Pict. 73), if not you have to adjust the forward pressure. **DON'T OPEN THE LENGTH ADJUSTMENT LOCK AS LONG AS A SKI BOOT IS FIXED IN THE BINDING.**

Place the ski boot in the open binding and rest the boot heel on the brake pedal. Lift the length adjustment lock (1) with a screwdriver and slide the heel until the heel cup just touches the boot. Lock the length adjustment by pushing it down. Latch the boot in the binding and check forward pressure again. The toe pincers should not be pressed

open and the indicating pointer should rest within the scribed area.

7. ADJUSTMENT

Use the FISCHER Rental Caliper to check and make sure that the boot meets international standards and is not damaged. standards and has no damage.



AFS JUNIOR: The Junior Line is suitable for both adult (type A) and children (type C) boots: the innovative mechanical Anti Friction Slider (AFS) automatically adjusts to the boot sole height, compensating A/C standards as well as height differences due to icing up, dirt or boot wear.



If you want to increase the stability of your junior binding in combination with children (type C) boots, you can replace the standard AFS with a vertically blocked AFS (Art. No.T162962), which is for children (type C) boots ONLY. All you have to do is to separate the standard slider from the base plate.



Afterwards you can simply click in the spare slider.



ADJUSTING THE RELEASE VALUES:

The release values at toe and heel should be determined by height and body weight (ISO/ASTM) method. Set the binding accordingly with the adjustment screws at heel and toe unit - therefore use a manual screwdriver. We recommend the use of a calibrated testing device and that you keep a written record of whether the system passes or fails (requirement in the US).

8. FUNCTION CHECK

Entry/exit: Check to make sure that the boot does not catch on the heel hold down lug.

Brake: Press the brake pedal (1) down by hand. The brake arms (2) must automatically return to the braking position when the treadle is released).



Lateral elasticity of the toe: Press the boot laterally outward. The binding must re-center the boot easily and quickly from a 10 mm lateral displacement.

9. FINAL CHECK

- Is the proper mounting point selected?
- Functional brake test passed?
- Are all screws fastened tightly?
- Is the forward pressure properly adjusted?
- Are the release values of the toe and heel properly determined and set?
- Is the instruction for use booklet ready to be handed over to the consumer?

DRILL TEMPLATE BASES & PLATES



1. COMPATIBILITY

Presently the drill template BASES & PLATES can be used for:

Racetrack	Rentaltrack
Powerrail	SLR
Womentrack	FP9

Drill template BASES & PLATES is for mounting of all types of plates and bases, except the RACEPLATES (Jr.) and SUPERLITERAIL (S, L). All bases and plates come with 8 mm penetration depth screws, except the RACEPLATE Junior, which comes with 6 mm penetration depth screws. For the SUPERLITERAIL bases the right screw set has to be ordered according to the ski specification. Drill template BASES & PLATES can be used for ski widths from 59 to 108 mm. For other skis use the template adapter set (Art. No. T162569). With this adapter set skis from 45 to 132 mm can be mounted.

2. POSITIONING OF THE DRILL TEMPLATE

Open the clamping jaws (3) by rotating the clamping handles (1) and then place the template on the ski. Align the boot midsole indicator (2) for the appropriate model with the midsole mounting mark on the ski. Be sure the template is evenly seated against the ski's top surface. Release clamping handles.

NOTE: Keep in mind that some ski manufacturers do not use the center of boot sole location method. Always follow the ski manufacturer's instructions.

3. DRILLING THE HOLES

If not otherwise specified by the ski manufacturer, for all bases use a 4.1 Ø x 9.0 mm drill bit for skis, groups G1 & G2. For skis of, groups G3 & G4, use a 4.1 Ø x 7.0mm drill bit.

DRILL THROUGH THE APPROPRIATE BUSHINGS

Model	Color of indicator
FP9	red
SLR M Womentrack	black
Rentaltrack Powerrail Racetrack	white

After drilling place a drop of FISCHER glue into the holes. It lubricates the screws and seals the holes.



4. PLATES

4.1 MOUNTING - PLATES

The compatible binding-plate combinations can be found in the compatibility chart. Place the front part of the plate over the holes and fasten the screws. Then place the back part over the holes and fasten the screws.



4.2. MOUNTING - BINDING ON PLATES

For mounting junior bindings on FISCHER PLATES, you have to replace the pre-mounted screws by screws of 8 mm penetration depth. The right pullout strength can only be ensured with these screws.

NOTE: Use only the pre-drilled holes for installation – do not drill holes into the plate to mount bindings of other manufacturers.

Determine the boot sole length with the FISCHER Rental boot caliper and place the binding on the plate corresponding with the appropriate printed length markings.



Mount the binding in accordance with the procedures in this manual.



NOTE: MOUNTING FISCHER BINDINGS ON RAISED PLATFORMS:

- Please note the FISCHER brake-matrix on the next page. There you will find a classification of all our brakes depending on stand height and weight. A brake is permitted, if the combination of stand height and weight hits the sector under the relevant curve. If not the brake has to be changed by a stronger one of a higher category. At all current FISCHER ski sets with FISCHER bindingplate-systems the included brakes fit these requirements. If you are combining FISCHER bindings and plates with product of other manufacturer please check the technical requirements of the ski – plate – binding – combination at the FISCHER brake matrix. There you will find out, if the desired combination of skiplate-binding is accepted or if you need to exchange the brake.

FOLLOW THE PROCEDURE BELOW:

1. Add the weight of the components you want to mount (ski + plate + binding).
2. Add the thickness of the components you want to mount (ski + plate + binding).
3. Find the value on the vertical axis which corresponds to the sum of the addition for the stand height.
4. Follow the horizontal axis on the matrix to the right until you find the value which corresponds to the total weight on the horizontal axis.
5. Use the lists at chapter "Technical Information" (page 9 et seq.), determine the standard FISCHER brakes of the binding and based on this information select the right curve at the matrix.
6. If the point of intersection of the weight and stand height lies below the respective curve, the brake will work properly.
7. If the point of intersection lies above the curve the brake must be replaced with the next stronger one.
8. If the point of intersection lies above the highest curve this combination of ski + binding + plate is not recommended. In this case, you have the following possibilities to come within the permitted range:
 - a) Reduce the total thickness through:
 - a thinner plate,
 - a FISCHER binding with less stand height.
 - b) Reduce the total weight to
 - a lighter plate,
 - a lighter ski.
 - c) Use a combination of a) + b).

Have a look to all technical specifications about FISCHER bindings and plates in chapter "Technical Information" – this will help you at finding an accepted combination.

4.3 FISCHER BRAKE MATRIX 16I17

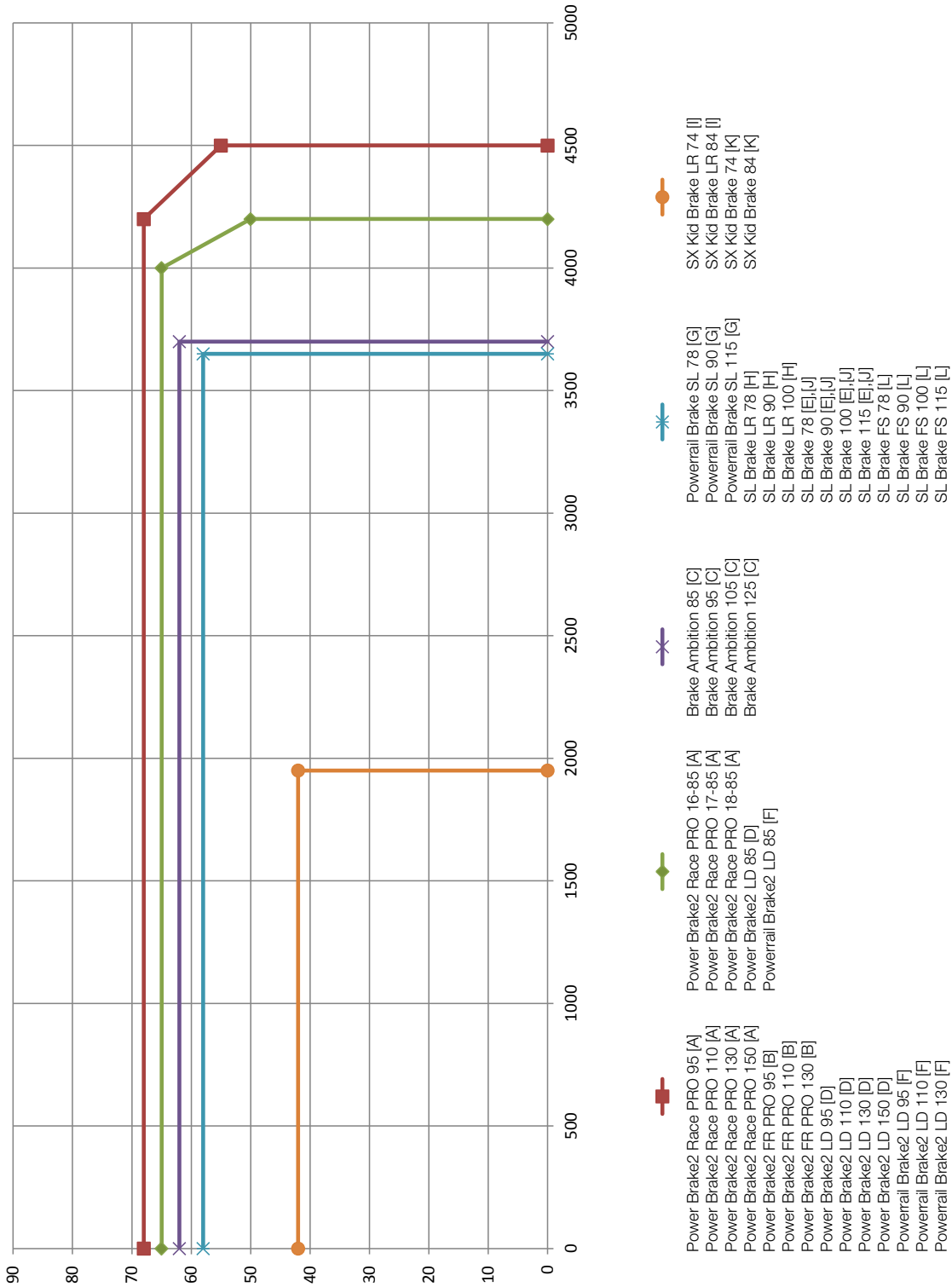

4.4 FISCHER BINDING-PLATE COORDINATION LINE 16I17

	CURV BOOSTER	WC Plate low	FP 9 Plate	RACEPLATE Junior
Height:	12.5 mm	13 mm	9 mm	11.5 mm
Mounting Range:	258-374 mm	258-372 mm	258-372 mm	238-342 mm
Mounting Range (SX):	241-330 mm	261-363 mm	261-363 mm	241-354 mm
Binding	Stand height (mm)			
RC4 Z 18 FF	29,5	30,0	26,0	28,5
RC4 Z 16 FF	28,5	29,0	28,0	30,5
RC4 Z 17 FF	28,5	29,0	28,0	30,5
RC4 Z 13 FF	33,5	34,0	30,0	32,5
RC4 Z 11 FF	33,5	34,0	30,0	32,5
RC4 Z 9	33,5	34,0	30,0	32,5
AAATACK 16	-	30,0	26,0	28,5
AAATACK 13	-	30,0	26,0	28,5
AAATACK 11	-	34,0	30,0	32,5
X 7 AC	-	34,0	30,0	32,5
RS10	-	34,0	30,0	32,5
RS 11	-	34,0	30,0	32,5
FJ 7 AC	-	34,0	30,0	32,5
ATTACK DEMO	-	35,0	31,0	33,5
XTR 10	-	44,0	40,0	-
XTR 7	-	44,0	40,0	-
XTR 10 Rent	-	-	31,0	-
FJ4 AC	-	-	-	-
XTR 4 AC Pro	-	-	-	-
XTR 4 Rent	-	-	-	-

5. POWERRAIL SYSTEM

The POWERRAIL system meets the demands of adult skiers, while being perfectly suited for both retail and rental sectors! All POWERRAIL bindings can be combined with both types of bases.

The standard base POWERRAIL consists of a monoblock base body and a cover with an inlaid toothed area. The cover can be colour matched to the ski design.



For unhindered natural ski flex, the base is secured by one fixed pair of screws, and three free-gliding pairs of screws. This ensures the base safely adapts to the flex of the ski.
NOTE: FISCHER offers different types of brakes for POWERRAIL bindings.

The Description of the brakes always includes a number like 78, 90, 97, 115, and so on This number stands for the maximum ski width in the brake area and not in the ski center!!!

5.1 MOUNTING - BASE

If the base is not already pre-mounted on the ski, you have to use the template Bases & Plates to mount it. Just select the right mounting mark and the appropriate bushings: the white mark and the silver bushings for POWERRAIL. The procedure is similar as for plates. After drilling, cleaning, tapping and lubricating you can put on the base. Place it over the holes and tighten all screws.



Finally you can snap in the appropriate cover.



5.2 MOUNTING - BINDINGS

Make sure that the boot is satisfying the international standards and has no functional damage. Take the binding parts out of the box and follow the steps on the instruction leaflet. Determine the boot sole length with the FISCHER/FISCHER rental caliper (Art. No. T162617).



FIRST INSTALLATION

Open the toe-lever and slide the toe on the rail from the front. Lock at the appropriate boot sole length and close the lever.



Now hook the brake into the heel housing.

Then open the heel lever, slide the heel on the rail from the back and lock it at the appropriate boot sole marking. Don't forget to check that the lever is closed again. Finally, check the forward pressure, by placing a boot into the binding. If you have followed all steps correctly, the indicator should rest in the marked area – and you are ready to go.



If you have too much or not enough forward pressure, check the settings and if necessary, adjust slightly at the heel and the toe. Then close the levers and check the forward pressure again. Now it should be okay.



ADAPTATION:

Once the binding is mounted onto a ski it is very easy to adjust it to another boot sole length. Just open the levers and slide toe and heel to the desired length mark. Finally close the levers and check forward pressure as described before.

5.3 MAINTENANCE & SERVICE

To provide unaffected long-term performance of the new POWER binding models, the toe and heel guides can be exchanged or retrofitted. These features ensure that steady function is guaranteed, even after massive use in rental.

6. ADJUSTMENT OF THE RELEASE VALUES

The release values at toe and heel should be determined by height and body weight (ISO/ASTM) method. Set the binding accordingly with the adjustment screws at heel and toe unit - therefore use a manual screwdriver. We recommend the use of a calibrated testing device and that you keep a written record of whether the system passes or fails (requirement in the US).

NOTE: Release/Retention settings above a release moment of 100 NM at the toe and 400 NM at the heel are higher than the international standards recommend and are used solely at the skier's own risk!

7. FUNCTION CHECK

Check the function of the heel. Make sure that the boot does not catch on the heel during entry and exit. Check the brake function by pressing down the brake pedal (1) by hand. The brake arms (2) must open to the braking position when the brake pedal is released.



Check the elasticity and retention of the toe by pushing the boot inward and outward. The binding must recenter the boot easily and quickly from a 15 mm lateral displacement.

8. FINAL CHECK

- Is the proper mounting point selected?
- Functional brake test passed?
- Have all screws been fastened tightly?
- Is the forward pressure properly adjusted?
- Are the release values of toe and heel properly determined and set?
- Is the Instruction for use booklet ready to be handed over to the customer?

DRILL TEMPLATE SUPERLITERAIL



1. COMPATIBILITY

Presently the drill template SUPERLITERAIL can be used for:

- SLR 2
- SLR 2 Junior
- SLR 2 Women

Drill template SUPERLITERAIL can be used for ski widths from 59 to 108 mm to mount SUPERLITERAIL Bases and SUPERLITERAIL II Bases. For other skis use the template adapter set (Art. No. T162569). With this adapter set ski widths from 45 mm to 132 mm can be mounted.

The SLR base (SuperLiteRail) is available in only one size, and it covers sole lengths ranging from 255 – 338 mm. The three sizes of the SLR 2 base (SuperLiteRail II) covers a boot sole range of 199 mm to 347 mm. All SLR Bindings are compatible with both bases – SuperLiteRail and SuperLiteRail 2 Base.

Version	Boot sole range
SLR BASE	255 - 338 mm
SLR 2 Base S	199 - 283 mm
SLR 2 Base M	239 - 323 mm
SLR 2 Base L	263 - 347 mm

Depending on the ski specification the appropriate screw set for the SLR and SLR 2 base has to be ordered. The following chart shows which Fischer bases and plates are suitable for the different ski-groups (G1-G4).

Model	G1	G2	G3	G4
SLR BASE	x	x	x	o
SLR 2 Base S	x	x	x	o
SLR 2 Base M	x	x	X	o
SLR 2 Base L	x	x	X	o

x...suitable o...not suitable

If bases and plates are mounted on other ski groups, the penetration depth and the torque moment of the screws have to be verified.

2. POSITIONING OF THE DRILL TEMPLATE

Open the clamping jaws (2) by rotating the clamping handles (1) and then place the template on the ski. Align the boot midsole indicator (3) for the appropriate model with the midsole mounting mark on the ski. Be sure the template is evenly seated against the ski's top surface. Release clamping handles.

NOTE: Keep in mind that some ski manufacturers do not use the center of boot sole location method. Always follow the ski manufacturer's instructions.

3. DRILLING THE HOLES

If not otherwise specified by the ski manufacturer use for all bases a 4.1 Ø x 9.0 mm drill bit for skis group G1 & G2. For skis of, groups G3 & G4, use a 4.1 Ø x 7.0 mm drill bit.

The front holes are identical for all versions. You just have to align the ski mid mark with the right indicator and use the appropriate bushings for the rear holes.

Version	Color of indicator / bushings
SLR Base	red
SLR 2 Base S 199 - 283 mm	yellow
SLR 2 Base M 239 - 323 mm	red
SLR 2 Base L 263 - 347 mm	black

After drilling place a drop of FISCHER glue into the holes. It lubricates the screws and seals the holes.

4. MOUNTING

4.1 MOUNTING - SUPERLITERAIL BASES

After drilling, cleaning and lubrication you can put on the base. Place it over the holes and tighten all screws in a cross pattern. Finally snap in the cover on the base.



4.2 MOUNTING - SUPERLITERAIL 2 BASES

Place the front part and rear part over the holes and tighten the screws carefully.



4.3 MOUNTING - BINDINGS

Mounting and adjusting the SLR bindings is extremely simple and can be done without any additional tool. Make sure that the boot meets the international standards and is free of any functional damage. Take the binding parts out of the box and follow the steps on the instruction leaflet. Determine the boot sole length with the FISCHER rental caliper (Art. No. T162617).



First you have to open the toe-lever and slide the toe on the rail from the front.



Lock at the appropriate boot sole length and close the lever.



Now hook the brake into the heel housing. Then you can open the lever and slide the heel on the rail from the back!



Simply lock it at the appropriate boot sole marking by closing the lever - and you are ready to go.



Finally, check the forward pressure, by placing a boot into the binding. If you have followed all steps correctly, the indicator should rest in the marked area.

If you have too much or not enough forward pressure, check the settings at first. If necessary, adjust slightly at the heel and the toe. Then check the forward pressure again. Now it should be okay.

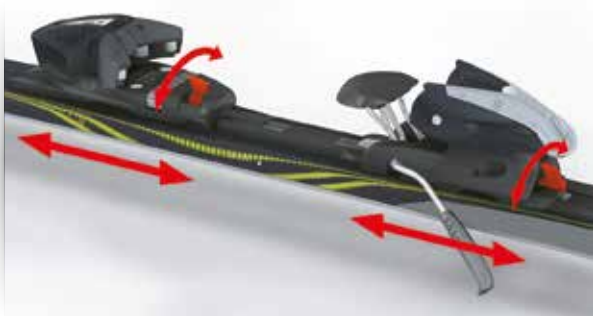

5. AFS JUNIOR ON DIN 7.5 AC AND DIN 4.5 AC MODELS

The SLR is suitable for both adult (type A) and children (type C) boots: the innovative mechanical Anti Friction Slider (AFS) automatically adjusts to the boot sole height, compensating A/C standards as well as height differences due to icing up, dirt or boot wear.



If you want to increase the stability of your junior binding in combination with children (type C) boots, you can replace the standard AFS with a vertically blocked AFS (Art. No. T162962), which is for children (type C) boots ONLY. All you have to do is to separate the standard slider from the base plate.



Afterwards you can simply click in the spare slider.



6. ADJUSTMENT OF THE RELEASE VALUES

The release values at toe and heel should be determined by the height and body weight (ISO/ASTM) method. Set the binding accordingly with the adjustment screws at heel and toe unit - therefore use a manual screwdriver. We recommend the use of a calibrated testing device and that you keep a written record of whether the system passes or fails (requirement in the US). **NOTE:** Release/Retention settings above a release moment of 100 NM at the toe and 400 NM at the heel are higher than the international standards recommend and are used solely at the skier's own risk!

7. FUNCTION CHECK

Check the function of the heel. Make sure that the boot does not catch on the heel during entry and exit. Check the brake function by pressing down the brake pedal (1) by hand. The brake arms (2) must open to the braking position when the brake pedal is released.



Check the elasticity and retention of the toe by pushing the boot inward and outward. The binding must recenter the boot easily and quickly from a 15 mm lateral displacement (FJ 7.5 AC, FJ 4.5 AC - 10 mm).

8. FINAL CHECK

- Is the proper mounting point selected?
- Functional brake test passed?
- Have all screws been fastened tightly?
- Is the forward pressure properly adjusted?
- Are the release values of toe and heel properly determined and set?
- Is the Instruction for use booklet ready to be handed over to the customer?

DRILL TEMPLATE XTR PRO

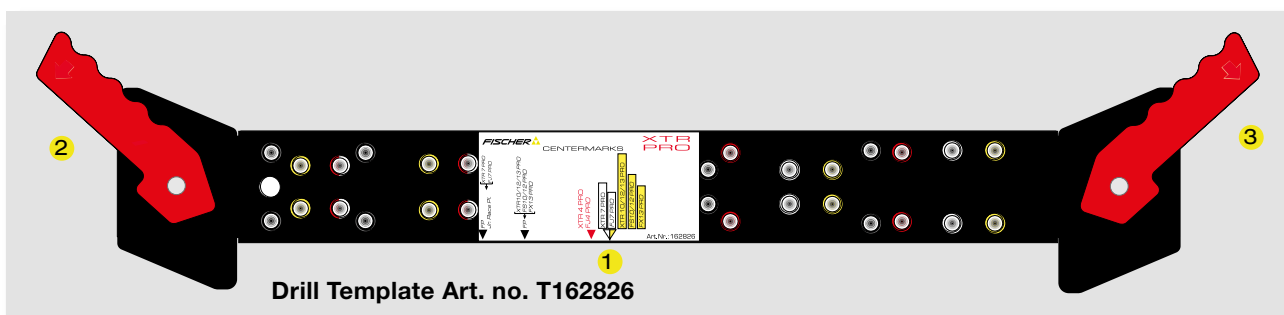

Drill Template Art. no. T162826

1. COMPATIBILITY

Presently the drill template XTR PRO can be used for:
XTR 10 Pro
XTR 7 Pro

All adult bindings come with 8 mm penetration screws and can be used with skis, of groups G1 & G2. The junior binding XTR 7 AC Pro is delivered with 6 mm penetration screws for skis, groups G3 & G4. If it is mounted on skis, groups G1 & G2, or on Fischer plates, replace them with longer screws.

Drill Template SP 2003 W can be used for ski widths from 59 mm to 108 mm, the drill template SP 2003 FAT for ski widths from 104 mm to 154 mm. For other skis use the template adapter set (Art. No. T162569). With this adapter set, you can mount skis from 45 mm to 132 mm with the standard SP 2003 W drill template, as well as skis from 90 mm to 178 mm with drill template SP 2003 Fat.

NOTE: Fischer offers different types of brakes. Refer to the brake overview for brake and binding compatibility.

The Description of the brakes always includes a number like 74, 78, 93 or 115. This number stands for the maximum ski width in the brake area and not in the ski center!!!

2. POSITIONING THE DRILL TEMPLATE

Open the clamping jaws by rotating the clamping handles and then place template correctly on the ski. Align the boot midsole indicator for the appropriate binding model with the midsole mounting mark on the ski. Be sure the template is evenly seated against the ski's top surface. Release clamping handles) and attach the template firmly to the ski.

NOTE: Some ski manufactures do not use the center of boot sole location method. Always follow the ski manufacturer's instructions.

3. DRILLING THE HOLES

If not otherwise specified by the ski manufacturer, for all Pro adult models use a 4.1 Ø x 9.0 mm - drill bit for skis of group 1 and 2. For XTR 7 AC Pro use a 4.1 Ø x 7.0 mm - drill bit for skis of group 3 and 4.

Model	Color of bushing
XTR 10 Pro	yellow
XTR 7 Pro	white

If required by the ski manufacturer, tap the hole. After drilling place a drop of glue into the holes. It lubricates the screws and seals the holes.

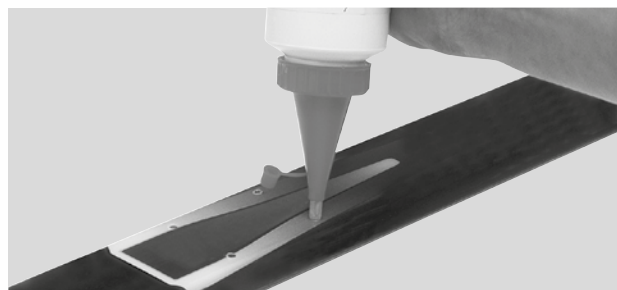

4. MOUNTING

Mounting the toe: Connect the plastic mid section with the metal toe track). Place the assembled toe track over the holes and tighten the screws. Open the one touch latch and slide the toe piece on from the front.

Adjust the toe piece to the desired SINGLE CODE position and close the latch. Make sure that the lever snaps in place completely (it may be necessary to slide the toe forwards and backwards slightly).

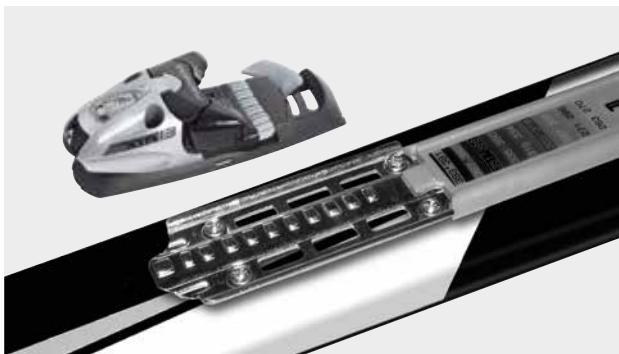

Mounting the heel: Place the heel unit with its brake, guide and track over the holes. Tighten the screws in an X-pattern.

5. FORWARD PRESSURE CONTROL

Place a suitable reference boot in the binding using the Single Code for length adjustment and close it. Then check the indicator located at the rear end of the heel piece. With boot inserted the pointer should rest in the middle of the scribbled area. If necessary, readjust the boot sole length, check the Single Code (1).

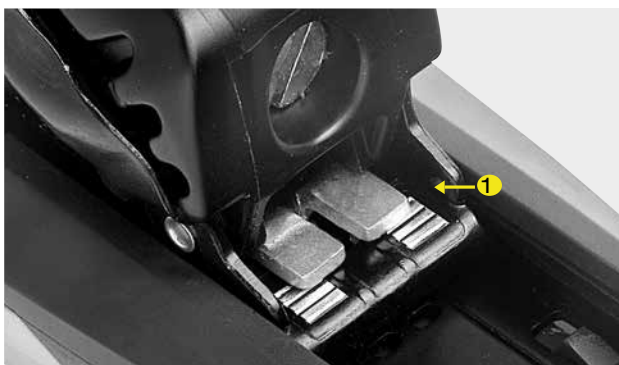

NOTE: Always remove the boot from the binding before adjusting.

6. ADJUSTMENT

FOR ALL MODELS:

Find adjustment ranges and some handling hints in the section "Rent" of the Technical Manual. Take at least one reference boot satisfying all standards and free of functional damages to perform test adjustments with the binding.



Using the Single Code: Adjust toe and heel to the corresponding alpha-setting (Single Code) of the ski boot.

If a boot of unknown size is used proceed as follows:

Place the boot in the toe cup. Slide the heel piece forward until it just touches the boot. Close the binding and check the forward pressure.

Adjusting the release values: The release values at toe and heel should be determined by height and body weight (ISO/ASTM) method. Set the binding accordingly with the adjustment screws at heel and toe unit - therefore use a manual screwdriver.

We recommend the use of a calibrated testing device and that you keep a written record of whether the system passes or fails (requirement in the US).

NOTE: Release/ Retention settings above a release moment of 100 NM at the toe and 400 NM at the heel are higher than the international standards recommend and are used solely at the skier's own risk!

7. FUNCTION CHECK

Before the newly mounted ski equipment is rented perform a complete functional check.

NOTE: In some countries rental equipment has to pass a Pre-Season Test (see the Rental section of this manual). The boot should not catch on the sole hold-down of the heel as it opens and closes.



Brake: Press the step-on plate (1) down by hand. The brake arms (2) must close and open automatically to the braking position when the step-on plate is released.

Lateral elasticity of the toe: Press the boot laterally outward. The binding must re-center the boot easily and quickly from a 15 mm lateral displacement. (XTR 7 AC Pro - 10 mm).

8. FINAL CHECK

- Has the proper mounting point been selected?
- Have all screws been fastened tightly?
- Has the forward pressure setting been controlled?
- Has at least one full adjustment been made using a representative reference boot including release/ retention setting and momentum test?
- Has the functional check been passed successfully?
- Functional brake test passed?

DRILL TEMPLATE XTR RENT

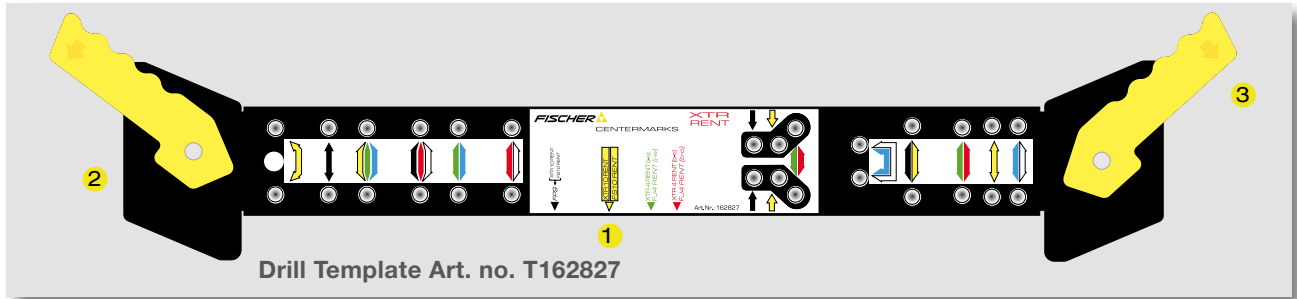

1. COMPATIBILITY

Presently the drill template XTR Rent can be used for:
XTR 4 AC Rent

XTR 4 AC Rent comes with 6 mm penetration screws and is only for skis, groups G3 & G4. Drill template XTR Rent can be used for ski widths from 59 to 108 mm. For other skis use the template adapter set (art. no. T162569). With this adapter set skis from 45 to 132 mm can be mounted.

NOTE: Fischer offers different types of brakes. Refer to the brake overview for brake and binding compatibility. The Description of the brakes always includes a number like 74, 78, 93 or 115. This number stands for the maximum ski width in the brake area and not in the ski center!!!

2. POSITIONING THE DRILL TEMPLATE

Open the clamping jaws by rotating the clamping handles and then place template on the ski. Align the boot midsole indicator for the appropriate binding model with the midsole mounting mark on the ski. Be sure the template is evenly seated against the ski's top surface. Release clamping handles and attach the template firmly to the ski.

NOTE: Some ski manufactures do not use the center of boot sole location method. Always follow the ski manufacturer's instructions.

3. DRILLING THE HOLES

If not otherwise specified by the ski manufacturer, for all Rent adult models use a 4.1 Ø x 7.0 mm - drill bit for skis of group G3 & G4.

Model	Colour of indicator
XTR 4 AC Rent	red (b-o)
XTR 4 AC Rent	green (j-w/F)

If required by the ski manufacturer, tap the hole. After drilling place a drop of glue into the holes. It lubricates the screws and seals the holes.

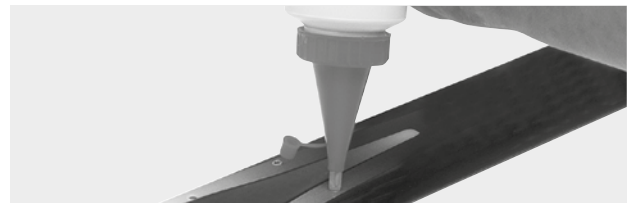

4. MOUNTING

Mounting the toe: Place toe piece on the prepared holes and drive the screws.

Mounting the heel: Place the heel unit with its brake, guide and track over the holes. Tighten the screws in a cross pattern.



5. FORWARD PRESSURE CONTROL

Place a suitable reference boot in the binding using the Single Code for length adjustment and latch it. Then check the indicator located at the rear end of the heel piece. With boot inserted the pointer should rest in the middle of the scribed area.

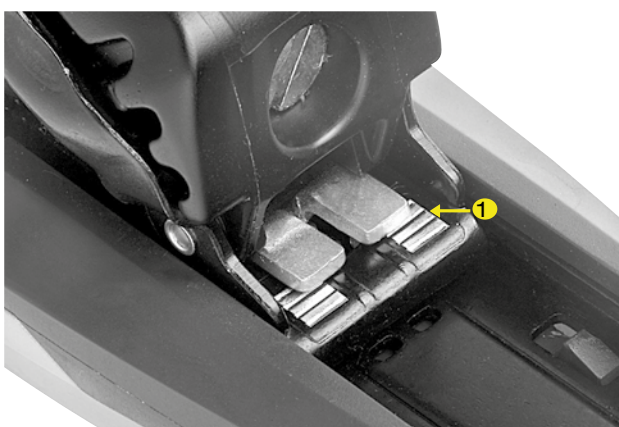

NOTE: If the forward pressure is not correct, readjust the boot sole length and check the Single Code. Please make sure that no boot is placed in the binding during adjusting!

6. ADJUSTMENT

FOR ALL MODELS: Find adjustment ranges and some handling hints in the section "Rent" of the Technical Manual. Take at least one reference boot satisfying all standards and free of functional damages to perform test adjustments with the binding.



Using the Single Code: Adjust toe and heel to the corresponding alpha-setting (Single Code) of the ski boot.

If a boot of unknown size is used proceed as follows:

Place the boot in the toe cup. Slide the heel piece forward until it just touches the boot. Close the binding and check the forward pressure.

Adjusting the release values: The release values at toe and heel should be determined by height and body weight (ISO/ASTM) method. Set the binding accordingly with the adjustment screws at heel- and toe unit - therefore use a manual screwdriver.

We recommend the use of a calibrated testing device and that you keep a written record of whether the system passes or fails (requirement in the US).

NOTE: Release/ Retention settings above a release moment of 100 NM at the toe and 400 NM at the heel are higher than the international standards recommend and are used solely at the skier's own risk!

7. FUNCTION CHECK

Before the newly mounted ski equipment is rented perform a complete functional check.

NOTE: In some countries rental equipment has to pass a Pre-Season Test (see the Rental section this manual). The boot should not catch on the sole hold-down of the heel as it opens and closes.



Brake: Press the step-on plate (1) down by hand. The brake arms (2) must close and open automatically to the braking position when the step-on plate is released.

Lateral elasticity of the toe: Press the boot laterally outward. The binding must re-center the boot easily and quickly from a 15 mm lateral displacement. (XTR 4 AC Rent - 10 mm).

8. FINAL CHECK

- Has the proper mounting point been selected?
- Have all screws been fastened tightly?
- Has the forward pressure setting correct?
- Has at least one full adjustment been made using a representative reference boot including release/retention setting and momentum test?
- Has the functional check been passed successfully?
- Functional brake test passed?

PRO-RENT ON THE SHOP FLOOR

PREPARING AND CHECKING RENTAL SYSTEMS

Customers usually don't treat rental equipment as gently and carefully as they would handle their private property. In order to keep your rental fleet as functional and appealing as possible, a systematic maintenance program is a must. The best results are obtained with an ongoing program which constantly checks boots, bindings and skis. To keep the equipment in good condition while minimizing liability we recommend the following program (this is a requirement in the U.S.). In order to produce a truly efficient rental inventory some pre-season setup is required.

Single Coding: This enables a quick boot and binding coordination even during the rush hours of rental business. Simply check the boot's Single Code and adjust the binding accordingly. In order to gain the efficiencies of FS, all you need to do is follow our simple procedure.

1. Mount all bindings accordingly to the FISCHER FS procedures. Pick a mounted sample binding of each model.
2. Place a boot of each size in the binding and adjust forward pressure until correct.
3. Open the heel and remove boot.
4. Record the Single Code from the track that corresponds to the mark on the side of the heel housing (the boot must not be in the binding when you read the code).
5. Check each code again before marking all boots of this size with their Single Code! For this procedure the FISCHER Rental Boot Indicator (art. no. T9043) can be used.



RENTAL INSPECTION SUMMARY

Since it is impractical to perform a full inspection each time a system is rented, a routine of pre-season and in-season inspections has been developed to verify release indicator accuracy, confirm correct equipment function, and assure proper assembly and adjustment procedures by the rental shop staff. Fully implemented, the procedures that follow provide rental shop customers a standard of care equivalent to that provided retail shop customers under current ISO and ASTM standards. The program is based on the existing standards: ISO 13993 and ASTM F1064.

PRE-SEASON INSPECTION

Pre-season inspections are performed on components of the release system: bindings and boots. All rental bindings, new and used, are visually inspected, and then tested using specially selected Reference Boots. Bindings that fail go through a trouble - shooting procedure to identify and correct the deviation or malfunction. If this procedure does not correct the problem, the binding is removed from inventory. All rental boots, new and used, are visually inspected for damage, wear, contamination, broken or missing parts, or inferior materials at contact points with the binding. In addition, one boot per "cell" is tested for boots that are new to the rental inventory. A cell is all boots of the same make, model, age, and shell size. A random selection of 5% of all boots, previously accepted into inventory, is also tested. Tests are performed with a test device and a pair of specially selected reference bindings. If a boot fails, all boots from that cell are then tested. Boots that fail and cannot be repaired are removed from inventory.

IN-SEASON INSPECTION

In-season inspection are performed on complete rental systems to ensure that the equipment is adjusted appropriately and continues to function correctly. Typically 5% of the rental inventory is tested during each two weeks sampling period. The random sample is equally divided between equipment that is available for rental and equipment that has just been rented. The equipment in the "as rented" category is from real skiers in the condition in which it is either dispatched or returned, while the "available for rental" equipment may be set up for fictitious skiers. Only single skis, not pairs, are tested, and testing at the toe is only required in one direction. A count is maintained of test results which exceed allowable limits. The magnitude and frequency of these deviations determines the frequency of future inspections. Shops which fail an inspection must sample daily until source of the problem is found and corrected. Then, as inspection results improve, the frequency of sampling and inspection is relaxed.

INSPECTION PROCEDURES

IMPORTANT TERMS

Correction Factor: The value that must be added or subtracted from the initial visual indicator setting to bring the result within the Inspection Tolerance (or Inspection Range).

Directions of Release: Unless otherwise specified (see Inseason Inspection), the directions of release to be tested are forward lean in clockwise and counter clockwise in twist.

Test Device: A device which meets ISO standard 11110 or ASTM standard F1061 and has been checked and maintained in the manner specified by the device manufacturer.

Test Result or Release Torque: The middle quantitative value of three tests made in the same direction.

PRE-SEASON TEST

Reference Boot Selection: The Reference Boot is a boot of a designated sole length which is otherwise typical of the boot inventory. Use the procedure below if the boot inventory includes several models and a representative boot can not easily be identified.

1. Select five single boots with sole lengths as specified in Table A for the binding type to be tested: adult, junior, or child.
2. Clean all five boots with a mild detergent and water.
3. Adjust a rental binding to the release indicator setting specified in Table A for the binding type.
4. Fit the binding to the boot and determine the Release Torque in all three directions of release (forward lean and both directions in twist—three releases in each direction).
5. Average the Release Torque for CW (clockwise) and CCW (counter clockwise) twist release.
6. Reject and replace any boot with a CW to CCW difference of more than 6 Nm for adult boots or 4 Nm when testing child boot types.
7. Rank the five twist results and select as the Reference Boot for twist, the middle boot.
8. Rank the five forward lean results and select as the Reference Boot for forward lean, the middle boot.

PRE-SEASON BINDING INSPECTION

The procedure that follows is an integral part of pre-season maintenance. It is also a good way to determine if maintenance and which units have outlived their usefulness and must be removed from inventory.

1. Clean areas of the bindings that contact the boot and perform all pre-season binding maintenance.
2. Visually or manually check:
 1. Clean areas of the bindings that contact the boot and

perform all pre-season binding maintenance.

2. Visually or manually check:
 - a) AFD condition.
 - b) Brakes' function.
 - c) Release indicator readability and travel.
 - d) Screw tightness.
3. Check that the heel track and toe track Single Code agrees with the sole length Single Code of the Reference Boot.
4. With the Reference Boot in the binding, verify elastic travel of the toe piece by striking the boot toe with a mallet or dead hammer and checking that the toe piece returns the boot quickly and completely to center.
5. Verify elastic travel of the heel piece by lifting the boot while depressing the heel piece cocking lever and checking that the heel piece returns the boot quickly and completely to the latched position.
6. Manually release the binding 3 times in each direction.
7. Lubricate all boot/binding interfaces with a mild liquid detergent and water solution.
8. With the Ski Binding Test Device determine the Release Torque for each direction of release (forward lean and both directions in twist).
9. Record "Pass" in the bindings's maintenance record if Test Results are within the Inspection Range provided in Table A.
10. Set the ski aside if the Test result in any directions of release is outside the Inspection Range in Table A.
11. Follow Troubleshooting Procedure on page 58 for units which have been set aside and retest if changes in the unit's condition or adjustment are made.
12. Record "Fail" in the binding's maintenance record if, after troubleshooting, test results in any direction of release are outside the In-Use Range. Replace the "failed" unit and retest before returning the ski to service.
13. If after troubleshooting, Test Results are outside the Inspection Range, but within the In-Use Range, apply a Correction Factor to the unit and note the Correction Factor for that unit in the binding's maintenance record.
14. If many bindings fail, check the test device and re-inspect the Reference Boot. If necessary, select another boot and retest the bindings.

Skicode	Binding type	Sole length mm	Release Indicator setting	Reference Indicator twist Nm	Reference torque forward Nm	Twist inspection range Nm	Forward inspection range Nm	Twist in-use range Nm	Forward in-use range Nm
TABLE A: PRE-SEASON BINDING INSPECTION									
F	Children	260	2,5	23	87	20 - 27	75 - 102	17 - 31	64 - 120
J	Junior	300	4,5	43	165	37 - 50	141 - 194	31 - 58	120 - 229
L	Adult	320	6,0	58	229	50 - 67	194 - 271	43 - 78	165 - 320

PRE-SEASON BINDING PREPARATION

The procedure that follows is an integral part of pre-season maintenance.

1. Clean all boots with a mild detergent and water, and repair or replace damaged or missing parts.
2. Visually check:
 - a) Conformance with ISO and other applicable standards-ISO 5355. If the boot contacts the binding, brake, or AFD in areas other than the designated contact points, it may be incompatible with the binding.
 - b) Boot material. If the sole at the contact points with the binding or AFD can be scratched with a finger nail, the boot may be of inferior quality and incompatible with the binding.
 - c) Boot sole condition. If the boot sole is damaged, worn, or contaminated at contact points with the binding or AFD in a manner which can not be corrected, the boot may be incompatible with the binding, "Verify boot sole dimensions".
 - d) Brake compatibility with sole.
 - e) Rubber and/or metal sole protectors. If such materials contact the binding or AFD the boot may be incompatible with the binding.
 - f) Mold flashings. Flashing which can be seen or felt at contact points with the binding, brake, or AFD must be carefully removed.
3. Remove from inventory all boots that have failed the visual check.

PRE-SEASON BOOT SAMPLING

Although sampling eliminates the need to test every boot before the season starts, the sample chosen must be representative of the inventory.

1. For boots that are new to inventory or have 1. never been inspected, take a single boot from each cell (a cell is all boots of the same make, model, year, and shell size).
2. For used boots, take a 5% (but not less than 16 or

more than 80) random sample of the entire inventory, see Table B.

Make sure that there is at least one boot from each cell in the sample.

PRE-SEASON BOOT INSPECTION

The procedure that follows helps to assure boot/binding compatibility and boot interchangeability.

NOTE: When using Table A, in the Boot Inspection procedures that follow, the Sole Length and release Indicator Setting columns should be ignored.

1. Randomly select a pair of bindings that have passed the pre-season inspection from each binding type; adult, junior, child.
2. Lubricate all boot/binding contact points with a mild liquid detergent.
3. Without regard to whether the boot is new or used, sort the sample by sole type and length according to the 20 mm Sole Length Categories defined by the Release/Retention Adjustment Chart.
4. In each Sole Length Category rank the boots by sole length and select the middle boot.
5. In each Sole Length Category fit the appropriate reference bindings to this "typical" boot and adjust the two bindings to release as close as practical to the Reference Torque in Table A. Use the Reference Torque corresponding to Skicode L for the Adult binding, J for Junior binding, and F for the Child binding.
6. Rinse the lubricant from one binding and mark it "clean". Mark the other "lubricated".
7. Test each boot in the Sole Length Category with the clean Reference Binding and then the lubricated Reference Binding in both twist and forward lean (only one direction in twist is required for the clean binding).
8. Set aside any boots for which the lubricated Test Result is more than 20% less than the clean Test Result in the

same direction of release or the lubricated Test Result in any direction of release is outside of the Inspection Range provided in Table A for Skicode used to set up the Reference Binding (L, J, or F).

9. Repeat the Visual check on all boots that have been set aside, correct any defects noted, and retest. Remove from inventory boots that fail the retest.

10. Check all other boots from the same cell (make, model, year and shell size) as those that failed.

NOTE: On completion of the pre-season inspection, clean the liquid detergent from equipment and lubricate the binding before returning it to service.

IN-SEASON SAMPLING AND INSPECTION

The In-season Inspection is a test of complete systems and all the procedures used by the rental staff to assemble and adjust the system. The program uses random samples of rental inventory taken at routine intervals. Any sampling program that gives every unit of inventory the same chance as every other of being picked is valid.

Sample Frequency: Random sampling is conducted throughout the entire season. Frequency is as follows:

1. After 7 days of operation.
2. If the sample passes the next sampling is taken after another 7 days operation.
3. If two consecutive samples pass, sampling frequency is increased to 14 days.
4. If a sample fails at any time, daily sampling is instituted until two consecutive samples pass, at which point weekly sampling resumes.

Sample Size: Sample size is 5% of inventory but not less than 16 nor more than 80 units as noted in Table B. Sample size is based on average daily output. If rental output drops below 50% of capacity over the sampling period, the sample size can reduced proportionately.

IN-SEASON INSPECTION

1. Take a random sample of the rental inventory as determined by Table B. Take half the sample from inventory as it is either rented or returned and the remainder from inventory available for rental.
2. The returned samples are tested with the last customer's data, the other samples adjust to randomly selected skier data. Consider already applied Correction Factors.
3. Wipe the boot clean and cycle the boot/binding systems at least once in each direction.
4. Test sample units in Twist (one direction only) and Forward Lean.
5. Compare the Test Results with the Inspection Range for the appropriate Skicode, see ISO 11088 Release/Retention Adjustment Chart (page 63).
6. If the results are within the Inspection Range, one value

above to one value below the reference value, the unit passes.

7. If the results are outside Inspection Range 07. but within the In-Use Range, two values 07. above to two values below the reference 07. value, count the unit as a Class I Deviation.

8. If the results are outside the In-Use Range, count the unit as a Class II Deviation.

9. Check elastic travel and visually inspect the ski brake function, interface areas between boot and binding, including AFD, lug height adjustment (if appropriate), and forward pressure. Count any deficiencies as Class I Deviations.

10. If more than the maximum number of Class I Deviations given in Table B are found in the sample, or a single Class II Deviation is detected the sample fails and daily sampling must be conducted until the problem which led to the failed sample is found and corrected. See page 58 for Trouble - shooting Procedures following a Failed In-season Inspection.

11. Record the date the sample was tested, the number of units tested the number of Class I and Class II Deviations, whether the sample passed or failed and any actions taken.

12. There is not need to record the identity of units tested or actual Test Results.

PRO-RENT ON THE SHOP FLOOR

RENTAL / DEMO OF PARTIAL SYSTEM

Many shops rent their customers partial ski equipment systems. Boots only if customers own their own skis with bindings, or skis and bindings if the customers own their own boots. Additionally some shops utilize on-hill "demo days" as a means by which new products can be tested and evaluated by potential buyers. In order to offer these skiers the same level of care as that afforded under the preceding procedures, the following guidelines should be used:

Rental of skis / Binding only:

Customer-owned boots: Although the retail test procedure may be applied in this case, it is often impractical to require actual system testing, especially in on-hill situations. In lieu of retail testing, the following procedures may be employed:

1. The ski/binding system to be rented or demoed should be tested "pre-season" using a boot which passes the FISCHER Boot Visual Inspection.

2. The skier's boot should also pass the Visual Inspection. If any questions exist regarding the quality of the boot, retail-type testing should be used.
3. The binding should be adjusted and its indicators set per current FISCHER recommendation.
4. A full record noting appropriate customer information and binding settings should be kept by the individual or organization responsible for the adjustment.
5. After seven days of use, the ski/binding system should be tested according to the In-Season Inspection Procedures previously described.

NOTE FOR US AND CANADA: Signatures by both the customer and FISCHER Certified Mechanic are required on all shop forms to qualify for the FISCHER Dealer Indemnity Program.

	Min.					Max.				
TABLE B										
Inventory Size - Pairs	50	100	200	300	400	500	600	700	800	900
Inventory Size - Units (half pairs)	100	200	400	600	800	1000	1200	1400	1600	1800
Sample Size - Pairs	16	16	20	30	40	50	60	70	80	90
Max. Class I dev.	3	3	4	6	8	10	12	14	16	16

BOOT HANDLING AND TESTING

VISUAL INSPECTION OF SKIBOOT

In assembling a system for the skier, it is the responsibility of the shop to inspect and evaluate each equipment component. This inspection checklist should be followed before any mounting or adjusting is performed. Ideally, they should be posted and used on the sales floor while the customer is still in the shop so that any deficiencies can be explained on the spot. In retail, boots must pass all four points of this inspection before being accepted for use. In rental, this inspection is the first step in the “pre-season boot test procedure”.

1. CHECK TYPE, SIZE AND OVERALL CONDITIONS

- Is the performance level appropriate for the skier?
- Is the size correct (Single Code, boot sole length)?
- Is all hardware intact and in working order?
- Is the boot free of excessive or asymmetric wear?
- Is the boot free of dirt or sole warp?

2. CHECK MATERIAL

- Binding contact surfaces require a high quality hard, lowfriction material. Check both lower shell and any separately attached inserts.
- If you can easily scratch the surface of the sole with your fingernail, that’s an indication of extremely soft material that can degrade system performance.

3. CHECK CONDITION OF BINDING CONTACT SURFACES, TOE AND HEEL

- Any scratches or other roughness should not be deeper than 1 mm.
- Check for any rocks, gum, or other foreign matter stuck to the sole.

4. VERIFY BOOT SOLE DIMENSIONS

- Skiboos must meet international standard specifications.
- Use the Boot Rental Indicator to determine whether wear is excessive. The most critical dimension for FISCHER bindings is the front surface and height of the boot toe. Any boots worn past the indicated amounts should be repaired or not used with FISCHER bindings.



THE FISCHER RENTAL BOOT INDICATOR

Art. no. T162617

This rental boot device is a multifunction-tool:

1. Sole length: Put the boot in the device and slide the toe stop up to the boot toe. Read sole length in the window, used for FISCHER rental bindings: the Single Code).
2. Boot sole wear: The standardized inter faces (contact bootsole with solelugs) are important in the functioning of FISCHER bindings.
3. Boot toe bottom: Excessive wear is indicated if the lower edge of the front surface is at or above the bottom step on the appropriate Child (C2), Adult (A2) or Touring (T2) post.
4. Boot toe ledge height: With the toe stop against the boot toe, the level of the toe ledge should be at or above the top of the appropriate post, “Child” (C1) or “Adult” (A1) or Touring (T1). Replace toe pads if worn.



5. Heel height and wear: Check this boot standard with the same procedure used for the toe. The heel posts (A3 + C3) are located at the rear of the device.

6. The marks "A/C" help to select a "Child" boot from an "Adult" by indicating the standardized sole width.

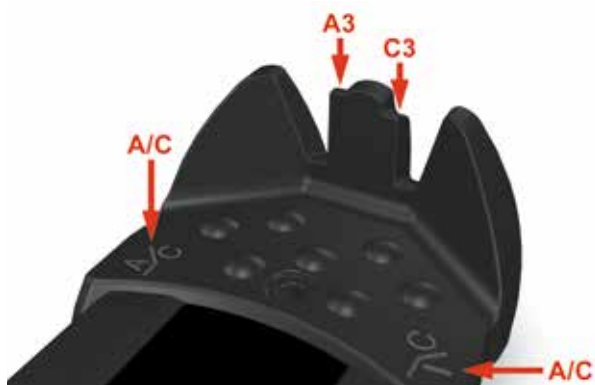

NOTE: Any boot which passes points 3, 4 and 5, as well as conforming to the Visual Inspection Checklist, may be accepted for use with FISCHER bindings. Boots which fail any point should be repaired or replaced. These checks apply only to boots used with FISCHER bindings. Consult other binding manufacturers for their used boot specifications.

CLEAN VS. LUBRICATED SKI BOOT TEST

This test is designed to determine the influence of a given boot on the release characteristic of a binding. It should be performed on boots not meeting all the points of the FISCHER boot visual inspection criteria, or if measured release values fall outside the system "inspection" tolerance. It is seen as the "last chance" for a boot to qualify before getting eliminated from inventory.

1. Clean the boot(s) to be tested with soap and water. Allow to dry.

2. Select an appropriate FISCHER "reference" binding that has displayed release values within the inspection tolerance on the FISCHER Adjustment Chart. Clean the binding's boot contact surfaces with soap and water and allow to dry.

3. Test the binding and boot in Twist and Forward Lean at a mid-scale indicator value (only one direction of twist is required).

4. In a further test run lubricate all boot/binding contact areas with soapy water. Retest in Twist and Forward Lean.
5. Results of each lubricated test should be within 20% of the corresponding results when tested clean. Any boot which fails this test should not be used with a FISCHER binding.

MAINTENANCE & SERVICE

1. VISUAL INSPECTION OF BINDING

In assembling a system for the skier, it is the responsibility of the shop to inspect and evaluate each equipment component. This inspection checklist should be followed before any mounting or adjusting is performed. Ideally, they should be posted and used on the sales floor while the customer is still in the shop so that any deficiencies can be explained on the spot.

2. CHECK SUITABILITY

- Is the binding model appropriate for the skier's ability?
- The binding must be compatible with the customer's boot/ski.
- The skier's release/retention setting should fall within the binding's adjustment range. Additionally, we recommend that the skier's setting not be closer than one number from the minimum or maximum settings on the binding in order to allow for future readjustment.
- Are the mounting screw lengths appropriate for the ski being used?

3. CHECK THE CONDITION OF BINDING

- Are all parts present and in working order?
- Is the AFD surface smooth and secure? If not, it should be replaced.
- Are all mounting screws present or tight?
- Does the binding show signs of contamination?
- Has proper periodic lubrication been performed? Dried out or corroded bindings can function improperly.

4. RETAIL TESTING

Completion and documentation of the following Retail Test Procedures is recommended for U.S.: required under the terms of the FISCHER Dealer Indemnity Program. These tests should be conducted any time work is performed on a ski/boot/binding system that may affect its release values. The procedure applies to all FISCHER alpine bindings, new as well as used.

1. Follow FISCHER procedures for inspection, mounting, adjustment, and maintenance as appropriate.
2. Confirm that toe and heel indicator values match those specified on the actual FISCHER Adjustment Chart.
3. Using a calibrated testing device, according to its instructions for use, "exercise" the binding by releasing it at least once in each direction (clock-wise and counter clockwise at the toe, vertically at the heel). Then measure Twist and Forward Lean Torque Values. The middle quantitative value of 3 releases in each direction should be used as the test result.

4. Compare Twist and Forward Lean test results with the System Inspection Ranges on the actual FISCHER Adjustment Chart.

5. If any test results fall outside the System Inspection Range, consult FISCHER Troubleshooting Procedures which follow this section.

6. With testing complete, the FISCHER Certified Mechanic must complete and sign the workshop ticket. Be sure the Final Indicator Settings are correctly shown there.

The workshop ticket should simply reflect that the system has "passed all tests" or that "all manufacturer's procedures have been completed".



5. REPLACING THE BRAKE

If the brake feels too hard or blocks during the hand test, if the brake arms are damaged, if the pedal is worn out or if a wider brake is necessary then the brake should be replaced immediately.

FISCHER offers different brakes for almost each binding. Refer to the brake overview for brake and binding compatibility.

To change the brake, all you have to do is to unscrew the old brake and replace it with the proper brake previously selected for the binding. In order to fix the brake, tighten the screws.

On most PowerRail and Literail bindings, the brake is hooked into the heel housing and not fixed with screws. Slide the heel off from the rails and replace the brake.



6. REPLACING THE GLIDE INSERTS

Powerrail Bindings: To provide unaffected long-term performance of the new POWERRAIL binding models, the toe and heel guides can be exchanged or retrofitted. These features ensure that steady function is guaranteed, even after massive use in rental.

Art.No. – T162950 Play Compensator PR TOE ABS

Art.No. – T162955 Play Compensator PR TOE AFS

Art.No. – T162951 Play compensator PR HEEL

To change the inserts just slide toe and heel off the rails and replace them with new ones. Lubricate the new inserts with FISCHER grease, clean the track, and slide toe and heel back in its original position on the rails.

7. LONG AND SHORT SCREWS:

Junior Bindings (DIN 7 or 7.5) are delivered with screws for skis, groups G3 & G4 (penetration depth 6 mm). If they are mounted on skis, groups G1 & G2 then the screws have to be replaced with longer screws. (penetration depth 8 mm).

8. TAPPING

FISCHER recommends tapping the drilled binding holes of any ski before mounting. Of course, there is a never-ending discussion among the mechanics if this is really necessary. But the pros are convincing:

- smooth and easy mounting
- reduced risk of stripping a screw
- same momentum adjustment of the screwdriver regard less of the ski material
- increased mounting quality/precision
- fewer pull outs.

9. TEMPLATE “ADAPTER”-SET:

1. For raised mounting positions

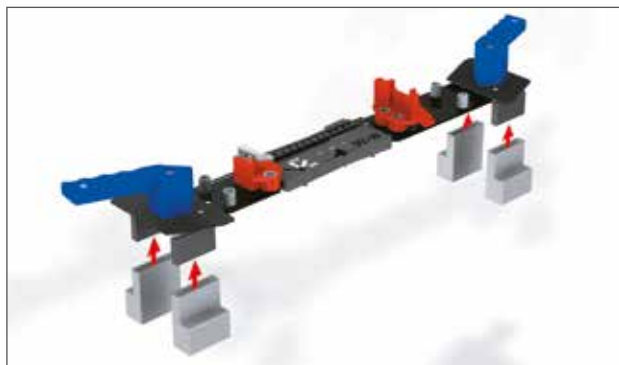

2. For wider mounting positions

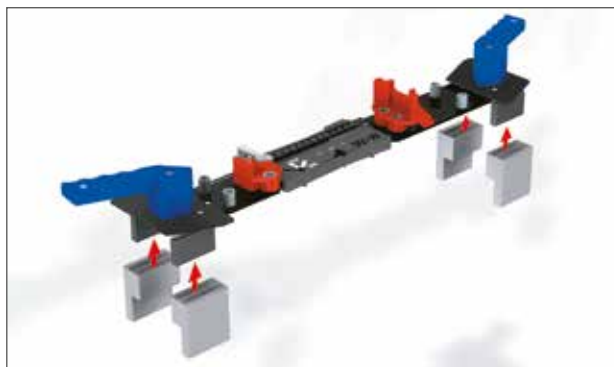

3. For narrower mounting positions

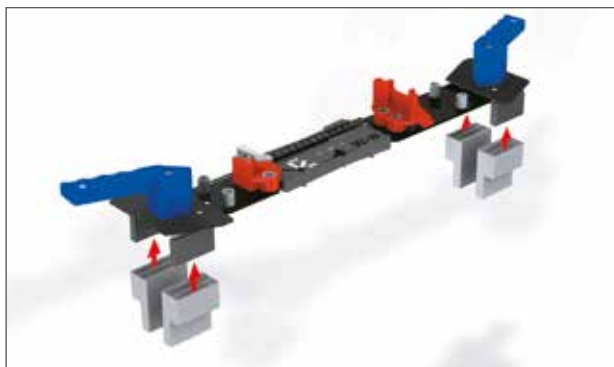

Compatible to all FISCHER-Templates. By using the template Adapter Set (Art. No. T162569) the mounting range of your template can be adapted depending on how you position the adapters on the drill template.

WARNING: Avoid dropping the template. The clamping jaws could be damaged.

Ski Type	Standard Drill Templates (59-108 mm)	FAT Drill Templates (104-154 mm)
Raised Mounting Position (see pos.1)	50-99 mm	95-145 mm
Wider Mounting Position (see pos.2)	83-132 mm	128-178 mm
Narrower Mounting Position (see pos.3)	45-94 mm	90-140 mm

10. RACING BINDINGS

Certain binding models are produced by FISCHER each year for the exclusive use of qualified competitors under the supervision of FISCHER Technical Specialists. These bindings are not covered by either the FISCHER Warranty or any Dealer Indemnity Program. We recommend you decline to service them, and warn against their use. DIN settings ≥ 10 do not satisfy the standard. Protection assertions are not applicable. Adjustments exceeding this range are made on one's own risk.

11. CLEANING AND LUBRICATING

Ski bindings need regular maintenance. Proper function is no longer insured if this procedure is not followed periodically.

- Please use only FISCHER recommended lubrication: FISCHER grease – T160052

FISCHER service – grease- spray – T162779

Both have the same content, but the grease tube is for more precise lubrication and the spray is suited for spots which are hard to reach with the tube.

- Clean the surfaces with a dry rag or warm water and mild soap.
- Avoid any contact with aggressive solvents or degreasers!
- Don't use cleansers!
- High pressure cleaning is not recommended. It might have the negative side effect of washing away the lubricating films.

11.1 LUBRICATING THE HEEL

Aero toes: Toe release indicator adjustment screw, guides of the main spring in the housing (with ServiSpray).

All Pro/XTR toes:

- In case of friction in the track system: Mark the toe position, open the FS hand lever and slide the toe piece off.
- Dry-clean the track and the toe guide base gently using a plastic brush.
- Then lubricate the locking mechanism at both sides of the toe guide base.
- Lubricate also both sides of the track guide over the entire length.



11.2 LUBRICATING THE HEEL

All Rental bindings: Mark heel position, open the guide lock with screwdriver, press hand lever and pull off the heel piece backwards.

Lubricate:

- Edge of the release cam under the heel lug as shown white in the fig. below (use grease).
- Both sides of the heel track (inside), entire length (use grease).



- The bearings of the opened hand lever, bottom side (use grease).
- The guiding channel of the release setting adjustment screw (use ServiSpray).



After finishing the heel lubrication slide on the heel and lock it in its original position.



11.3 FJ 4 AC AND XTR 4 AC Rent

Lubricate:

- both sides of the heel track (inside) over the entire length.
- the contact areas between housing and the release cam on the frontside and the backside.
- the guiding channel of the release setting adjustment screw.

After finishing the heel lubrication slide on the heel and lock it in its original position.



11.4 NOT TO BE LUBRICATED

The locking element and the corresponding holes in the heel track should be cleaned, but not lubricated. This could prevent dirt accumulation in this area, which could interfere with the ease of handling.

12. TEST YOUR DRILL TEMPLATE

A worn or damaged drill template could create a lot of trouble. Please check your templates periodically:

1. Position the fully extended drill template on a discarded ski.
2. Turn the clamping lever to open the clamping jaws of the mounting template.
3. Position the template properly on the ski so that the boot center marking is aligned with the mounting point described on the ski.
4. Let go of the clamping lever. The template clamps automatically.

5. Drill all the holes.
6. Remove the mounting template and clean the ski.
7. Measure the holes with a slide gauge.
8. The distance of the screw holes to the edge of the ski must be equal for each pair of related holes. The deviation must not be more than 1mm.
9. The mounting template must be discarded if greater deviations occur!

13. REPAIR OF DAMAGED MOUNTING HOLES OR BROKEN SCREWS

For repairing damaged holes, we suggest our special "Repair Set" – art. no. T162127. It consists of a hollow



drill bit and plastic inserts. You can extract broken screws too. Remove the binding from the ski.

Drill with the hollow drill through the bushing of the appropriate drill template and drive in the plastic insert. Mount the binding again.

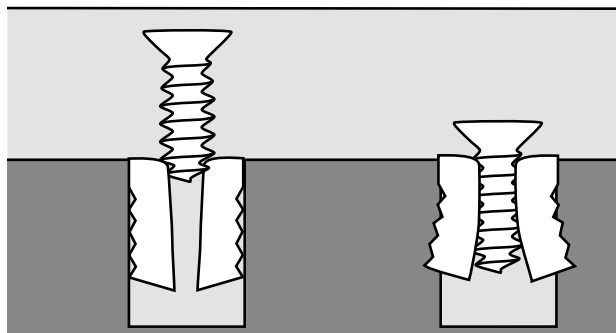

14. SEALING OLD MOUNTING HOLES

For sealing old holes you can use wood plugs or plastic plugs (art. no. T160857), if not otherwise specified by the ski manufacturer.

TROUBLESHOOTING (INCLUDING RENTAL)

Problem	Possible Reason	Solution
Difficulty when stepping in	Non-standard bootsole	Test and select a new boot
	Forward pressure too high	Readjust according to instructions
	Brake jams	Clean & lubricate; replace
Brake does not retract	Obstruction under the brake	Remove, clean, lubricate
	Brake arm bent	Replace brake
	Ski obstructs brake	Replace standard brake with wider brake, accordingly to ski width
Boot fails pre-season test	Low-quality boot material	Replace boot
	Excessive wear or contamination	Clean, repair or replace boot
	Reference binding worn	Recheck reference binding with a boot that has passed
	Boot does not meet ISO 5355	Replace boot
	Improper use of testing device	Check calibration and operating technique
Excessive in-season class I or class II deviations	Excessive boot sole wear or contamination	Clean, repair or replace boot
	Inadequate binding service	Conduct recommended maintenance every 15-20 days of use
	Improper use of testing device	Check calibration and operating technique
	Indicator correction factor needed	Test system according to pre-season testing Define indicator correction factor for subsequent adjustments
Single Code on binding interferes Single Code on boot	Incorrect template adjustment used when mounting	Set template to proper length and remount heel
	Incorrect track guide scale chosen mounting position	Choose binding according to given for given mounting position
Pro toe wobbles in this track	Toe locking lever not properly engaged in locking holes	Remove toe, clean track. Be sure toe piece locks into place
Freeflex-drill pattern not fitting	Toe / equalizing bridge in wrong position	Dismount, place toe in correct position
	Drill template not locked	Readjust, drill new holes
Heel slides backwards when customer steps in	Rear locking lever not fully closed or boot length exceed adjustment range	Lever shutt fully engage locking teeth inslots on track or boot sole length exceeds binding range
Binding fails pre-season test: release values too high or too low	Reference boot contaminated or worn	Clean or replace boot as indicated Indicated by clean vs. lube test result
	Forward pressure set incorrectly	Readjust to FISCHER recommendations
	Incorrect or off-center-mounting	Check the template. Remount using template correctly
	Improper use of testing device	Check calibration and operating technique
Adult bootsole does not fit into Junior toe lug	Boot sole exceeds the standard tolerance	Clean ADF and bootsole, check standard tolerance
Race Pro or Powerrail wobbles in the track	Heel glide inserts worn	Remove heel and replace plastic heel guides

CLASSIFY YOURSELF

DETERMINING YOUR SKIER TYPE IS YOUR RESPONSIBILITY!

Your Skier Type, height, weight, age and boot sole length are used by the shop technician to determine the release/retention settings for your bindings. Consult these descriptions to select your classification. Be sure to provide accurate information. Errors increase your risk of injury.

Skiers who designate themselves as Type I receive lower than average release/retention settings. This corresponds to an increased risk of inadvertent binding release in order to gain releasability in a fall.

This type also applies to entry level skiers uncertain of their classification.

TYP I:

Skiers who designate themselves as Type II receive average release/retention settings appropriate for most recreational skiing.

TYP II:

Skiers who designate themselves as Type III receive higher than average release/retention settings. This corresponds to decreased releasability in a fall in order to gain a decreased risk of inadvertent binding release.

Type III settings should not be used by skiers of less than 22 kg/48 lbs.

TYP III:

If you are unsatisfied with the release/retention settings that result from your classification please mention this to your binding technician.

NOTE:

If the skier reports release/retention problems see the chapter "trouble shooting release/retention problems", page 98 in the manual.

Skiers who desire release/retention settings lower than Type I may designate themselves (I-). Type I- is inappropriate for skiers 17 kg/38 lbs or less. Type I-: Move up the table one skier code.

Skiers who desire release/retention settings higher than Type III may designate themselves (III+). Type III+: Move down the table three skier codes.

Skiers may select skier type designations that are different for twist and forward lean. In such a case, the selection shall be indicated by a slash separating twist and forward lean selections, in that order (for example, K/L, K for the toe and L for the heel.

RELEASE/RETENTION ADJUSTMENT TABLE

NOTE: The initial indicator values found in this table are only the starting point in the binding setting process. The initial

values may need to be modified in order to achieve the correct measured release values.

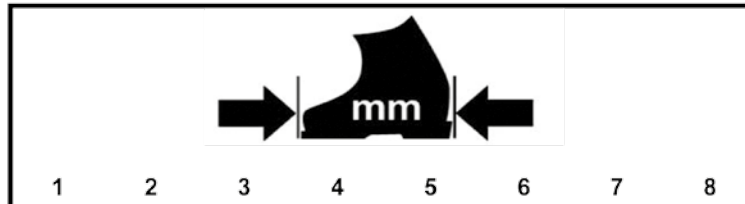

		SINGLE CODE								Mz (Nm)	My (Nm)	
		SKIER CODE	a-i	j-n	o-s/B	t/C-G	H-L	M-Q	R-V	V-6		
kg (lbs)	cm (ft'in")		≤230	231-250	251-270	271-290	291-310	311-330	331-350	≥351		
10-13 kg (22-29 lbs)		A	0,75	0,75	0,75						8	29
14-17 kg (30-38 lbs)		B	1,00	0,75	0,75	0,75					11	40
18-21 kg (39-47 lbs)		C	1,50	1,25	1,25	1,00					14	52
22-25 kg (48-56 lbs)		D	2,00	1,75	1,50	1,50	1,25				17	64
26-30 kg (57-66 lbs)		E	2,50	2,25	2,00	1,75	1,50	1,50			20	75
31-35 kg (67-78 lbs)		F	3,00	2,75	2,50	2,25	2,00	1,75	1,75		23	87
36-41 kg (79-91 lbs)		G		3,50	3,00	2,75	2,50	2,25	2,00		27	102
42-48 kg (92-107 lbs)	≤148 cm (≤4'10")	H			3,50	3,00	3,00	2,75	2,50		31	120
49-57 kg (108-125 lbs)	149-157cm (4'11" - 5'1")	I			4,50	4,00	3,50	3,50	3,00		37	141
58-66 kg (126-147 lbs)	158-166 cm (5'2" - 5'5")	J			5,50	5,00	4,50	4,00	3,50	3,00	43	165
67-78 kg (148-174 lbs)	167-178 cm (5'6" - 5'10")	K			6,50	6,00	5,50	5,00	4,50	4,00	50	194
79-94 kg (175-209 lbs)	179-194 cm (5'11" - 6'4")	L			7,50	7,00	6,50	6,00	5,50	5,00	58	229
≥95 kg (≥210 lbs)	≥195 cm (≥6'5")	M				8,50	8,00	7,00	6,50	6,00	67	271
		N				10,00	9,50	8,50	8,00	7,50	78	320
		O				11,50	11,00	10,00	9,50	9,00	91	380
		P						12,00	11,00	10,50	105	452
											121	520
											137	588

RELEASE/RETENTION ADJUSTMENT TABLE

HOW TO USE THE RELEASE/RETENTION ADJUSTMENT TABLE

1. Determine the Skier Code by locating the skier's weight in the first column and the skier's height in the second column. If the height and weight are not on the same line select the Skier Code closer to the top of the chart.
- 2 a. The Skier Code found in step 1 is for Type I skiers. For Type II skiers move down the chart toward the bottom one Skier Code. For Type III skiers move down two Skier Codes.
- 2 b. If the skier is age 50 or older or under 10 move up the chart one Skier Code toward the top. For skiers 13 kg/29 lbs and under, no further correction is required.
3. Find the column that corresponds to the skier's boot sole measurement in millimeters.
4. The value where the Skier Code and the boot sole measurement intersect is the initial indicator setting for the skier. If the intersection of the row and column falls in a blank box, do not move up or down the chart. Move sideways on the same row to the nearest box showing a visual indicator setting.
5. This value should be recorded on the workshop form under Initial Indicator Settings.

MECHANICAL SYSTEM TESTING

1. Adjust the bindings toe and heel indicators to the Initial Indicator Setting.
2. Use a calibrated torque measuring device according to the instructions provided by the supplier.
3. Exercise that binding by release it at least once in all direction.
4. Three tests are required in each direction. The middle quantitative value of the three releases should be used as the test result.
5. Using the previously determined Skier Code slide across the chart to the column representing twist torque reference values.
6. If the test result is within one torque value above to one torque value below the reference value, it is in the Inspection Range. These results are acceptable and no further adjustment is necessary.
7. If the test result is within two torque values above to two torque values below the reference value, it is in the In-Use Range. The indicator value should be readjusted and the system retested so that it falls in the Inspection Range. Record the corrected indicator value in the box for final release/retention settings.
8. If the test result value falls out of the In-Use Range the system should be thoroughly inspected for the following:
 1. Correct forward pressure
 2. Correct Sole-hold down adjustment
 3. Worn or contaminated AFD's
 4. Out of standard boot soles

No work can be performed on the system until these problems are corrected.

9. Check the heel for forward lean the same way, determining the middle quantitative value of three vertical releases. Adjust if necessary.

10. Record final indicator settings on the workshop form in the area for final release/retention settings.

TROUBLESHOOTING RELEASE/RETENTION PROBLEMS

IF THE SKIER REPORTS A RELEASE OR RETENTION PROBLEM:

- Re-inspect the equipment to make sure that all components are in good condition and function properly.
- Test the system to make sure that it is calibrated properly.
- Have the skier use the “Classify Yourself” materials to make certain that the correct Skier Type has been selected.

If component inspections and a calibration check do not reveal a problem the skier may be requesting discretionary settings.

INFORMATION FOR SKIERS REQUESTING DISCRETIONARY SETTINGS.

1. Your normal release/retention settings comply with ISO/ASTM standards. Although these guidelines may be inappropriate for some types of competitive skiing or competition training, they are believed to provide an effective compromise between the release and retention needs of most recreational skiers.

2. Adhering to these guidelines may help to reduce the risk of injuries resulting from improper release/retention setting selection. However, skiing involves inherent risks. Injury can result from simply falling down, impact with an object, or from many other actions. Many injuries are unrelated to the function of the release system. Furthermore, even a properly adjusted binding cannot protect the skier in all situations.

3. Difficulties with release or retention may be unrelated to release/retention settings and can result from your skiing style, the incompatibility of your boots and bindings, or wear, damage, or contamination of a component of the release system. Be sure to describe your circumstances to the shop technician and to authorize recommended inspections and repairs before proceeding.

4. If you have been dissatisfied with the release/retention settings that result from your normal skier classification, you may wish to consider changing your skier classification, or designating skier type classifications that are different for twist and forward lean. You may even request discretionary release/retention settings that are outside of your setting range. If you believe that you require higher release/retention settings but are unsure if the increase should be applied to twist or forward lean settings, request that the increase be applied to forward lean settings before experimenting with higher twist settings. Similarly if you believe that you require lower release/retention settings but are unsure if the decrease should be applied to twist or forward lean settings, request that the decrease be applied to twist settings before experimenting with lower forward lean settings.

Lower settings correspond to an increase in the risk of inadvertent binding release in order to gain increased releasability in a fall.

Higher settings correspond to a decrease in releasability in a fall in order to gain a decreased risk of inadvertent binding release.

5. Although the shop technician may help you to record your choice on the appropriate form, the final decision on your release/retention settings is yours.

A large area of the page consisting of multiple horizontal lines, intended for handwritten notes or text.

VACUUM

ADAPTABLE SKIBOOTS



THE ORIGINAL.

VACUUM STATION

The Fischer VACU-PLAST material enables for the first time a completely anatomical adjustment of the boot with a quality never reached before. And all that in 20 minutes. The 100% guaranteed fit you can achieve as a result was awesome for both the skiers and Fischer's selected retail partners.



VACUUM BOX

Based on the same technology, boots featuring this technology likewise enable the individual adjustment of the shell but the targets are different: the 16-minute fitting procedure achieves a sporty, comfortable fit which is unrivalled in this segment.



VACUUM FULL FIT PROCESS



WARM-UP

- Heat up the shell to 80 degrees Celsius in the oven



PRE-FIT

- Insert foot into preheated shell.
- Put on Cooling Pad and Compression Pad.
- Adjust the stand position on the VACUUM FULL FIT Station.



PERFECT FIT AND COOL DOWN

- Adjust the entire boot to the anatomy of the foot using compressed air.
- Use the Cooling Pad to cool it down.



VACUUM COMFORT FIT PROCESS



HEATING PERIOD

- Shell heating with blanket warmer technology as tried and tested in motor sport.

FULLY ADAPTABLE
+/- 5 mm



FORMING PROCESS

- Placing of Cooling Pad and Compression Pad.

EXPENDABLE ADAPTABLE
+ 5 mm



PARTIAL FITTING OF HEEL AREA

- Adaptation of heel area to foot anatomy using compressed air.

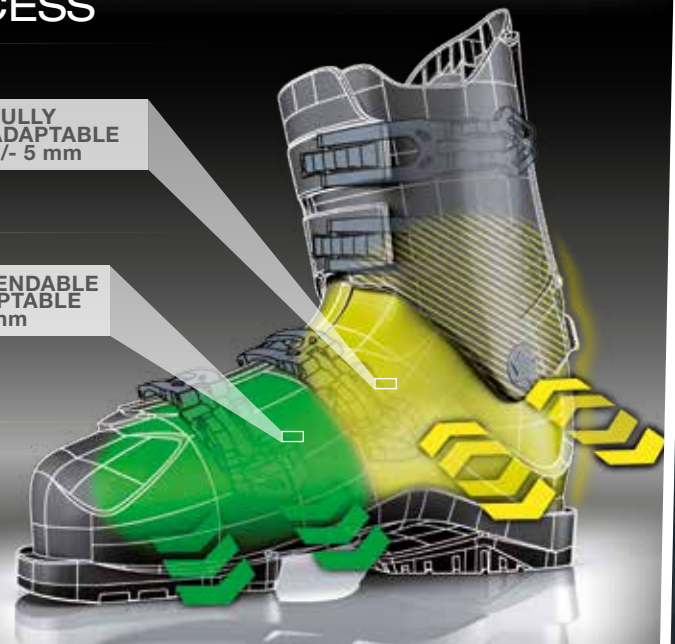

FITTING TOOLS



UPGRADE KIT VACUUM FULL FIT STATION VACUUM FULL FIT LINER ATHLETE FIT

Article no. U81514, XS-L

Development from racing for the VACUUM thermoforming of RC4 Pro and RC4 140. Athlete Fit liners are intended for the thermoforming process and are NOT SUITABLE for skiing. The shell is pressed even tighter to the anatomy of the foot. The result is an even more precise, better fit and more performance.



VACUUM TOE CAPS EXTENDED

Article no. U80114

Extended toe caps recommended for the VACUUM shaping process to create adequate space in the toe section. Another advantage is that the heel is pushed back better into place.



UPGRADE KIT VACUUM FULL FIT STATION 2ZONE

Article no. U81714

Existing VACUUM stations can be upgraded with VACUUM 2Zone technology by means of an Upgrade Kit. The Upgrade Kit consists of:

- 2Zone Compression Pads in three sizes (22.5-25.5 / 26.5-28.5 / 29.5-31.5)
- A new control system with an additional compressor
- An air distributor for both pressure zones

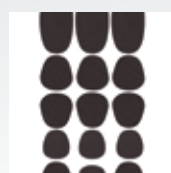

VACUUM FULL FIT PAD SYSTEM 6MM HIGH DENSITY

Article no. U80214

LISTEN TO YOUR FEET - SIMPLY STANDING NATURALLY

In keeping with the motto „Listen to your feet“, all our ski boots feature SOMA-TEC. Thanks to the natural V position of the feet, this technology harnesses the power in the boots and protects joints. For more energy-saving skiing, perfect power transfer and a natural motion sequence.

MAXIMUM POWER TRANSFER



SOMA-TEC harnesses all power exactly in the skiing direction.

- Perfect power transfer
- Maximum acceleration
- Less effort required



ON CENTER POSITION



The stand position lies exactly on the centre of the ski.

- Perfect edge grip
- Faster and easier edge switches

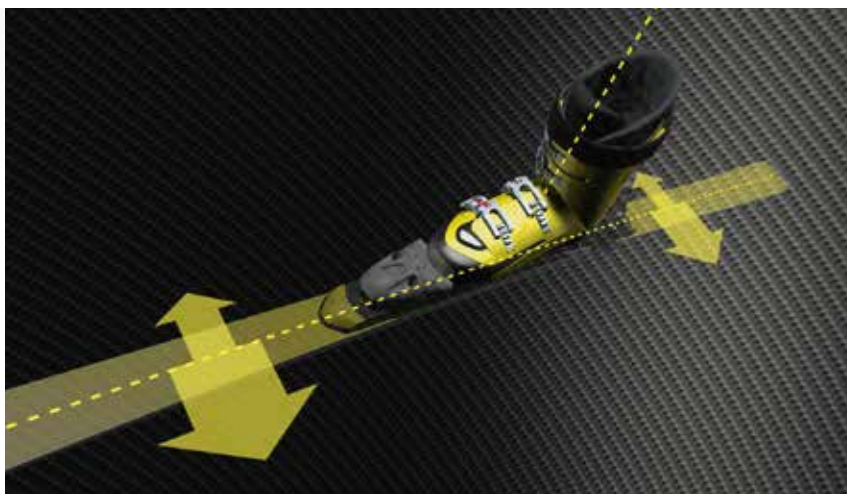

ORIGINAL V-POSITION



The natural V-position of the feet is retained inside the boot.

- Better control
- Less strain on joints
- The natural motion sequence is retained

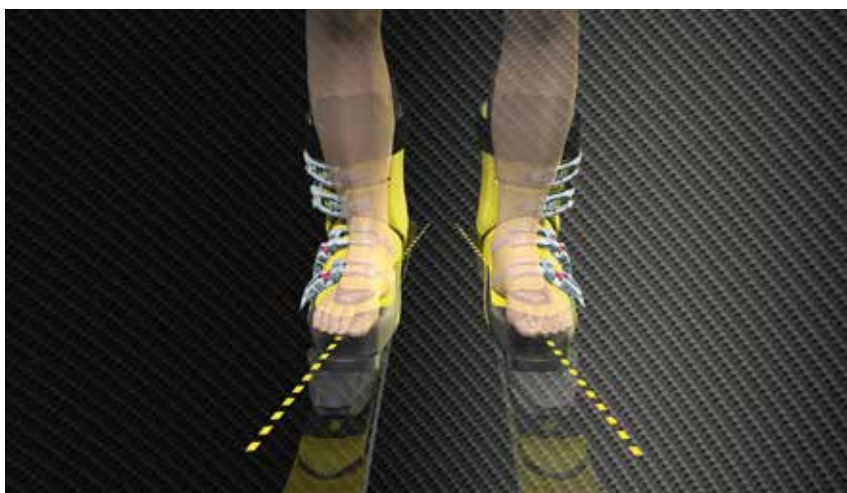

AFZ

ACTIVE FIT ZONES

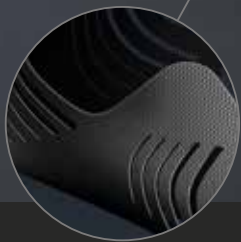

POWER ZONE

MORE POWER
TRANSMISSION FOR
MORE PERFORMANCE

The anatomic frame which is made of thicker material transfers power to the outer boot and thus enables optimum control. Pressure-sensitive areas of the foot are additionally relieved by the frame.



FLEX ZONE

A FIT MEANT FOR
EVERY MOVEMENT

Elastic transition points between hard and soft zones plus a flexible 3D shape in the ankle area ensure a perfect fit also while you are skiing.

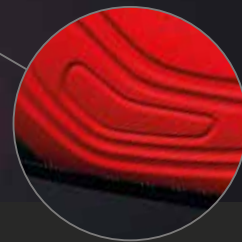

COMFORT ZONE

MORE COMFORT FOR
MORE PERFORMANCE

High-insulation cushioning material protects and warms the areas of the foot which are sensitive to pressure and the cold for greater comfort and more performance.

THE FIRST BOOT LINER WITH AN ACTIVE FIT

The **Fischer Active Fit Zones Liner (AFZ)** with 2K technology actively supports the foot in three defined function zones. The result: more comfort and performance thanks to a perfect fit which adapts dynamically to the movements and the anatomy of the foot.

FISCHER CERTIFICATION REQUIREMENTS

This section must be read, and thoroughly understood, prior to completion of FISCHER's Employee Training Documentation Form.

At FISCHER we realize that the quality added to our products in your shop is every bit as important as the quality we build in at the factory. The FISCHER Retailer Indemnity Program, which includes in depth technical training, is a key element of maintaining consistent quality.

TECHNICAL INFORMATION

Procedures for installation, release/retention adjustment, testing, troubleshooting and record keeping should always be taken from the current season's FISCHER Technical Manual.

EMPLOYEE TRAINING

This manual provides a depth of information unprecedented in the industry, it is here to help you fulfill the shop's responsibility to bring new employees to a basic level of competence. It also addresses our desire to provide information specific to selling, installing, function checking, and maintaining FISCHER products. Last but not perhaps most important, we produced it to help you understand why FISCHER represents the state of the art in bindings. We hope you will use it as part of a well planned and professional employee training program which goes far beyond properly installing bindings. Done well it will translate into consistent quality and the high level of satisfaction your customers deserve. Look at it as one of the first steps in your Total Quality Management program.

NOTE: Hands on training is the best training – An ideal task that can be incorporated into the training is pre-season testing. This will give your trainees hands on experience operating a testing device and adjusting ski/boot/binding systems. Other tasks, such as routine rental maintenance, can also be done during the training period.

SHOP REQUIREMENTS

Each retail location must have:

- A current FISCHER Authorized Retailer Agreement on file with FISCHER USA / Raymond Lanctot LTD, Can.
- A current FISCHER Binding Indemnification Agreement on file with FISCHER USA / Raymond Lanctot LTD, Can.
- At least one FISCHER Certified Technician employed per location.
- The required equipment for installing and testing FISCHER bindings. All Agreements and Certifications must be valid for the current season.

REQUIRED SERVICE SHOP TOOLS

This list is the bare minimum a shop can survive with.

- Tape Measure
- FISCHER Templates
 - Drill template 92 W or 92 FAT (Blue)
 - Drill template AAAMBITION (Brown)
 - Drill template AAADRENALIN (White)
 - Drill template 94 W (Violet)
 - Drill template LITERAIL (Green)
 - Drill template BASES & PLATES (Grey)
 - Drill template XTR Pro(Red)
 - Drill template XTR Rent (Yellow)
- Dynafit Jig - Tour Classic, Freeride
- Dynafit Jig - Tour Race, Speedlite
- Variable speed, reversible electric drill
- FISCHER Step Drill Bits (or equivalent)
 - 4.1 Ø x 9.0 mm
 - 4.1 Ø x 7.0 mm
 - 3.5 Ø x 9.0 mm
 - 3.5 Ø x 7.0 mm
- Tap, Tap Brace and Tap Guide
- FISCHER Pozidrive No. 3 screwdriver (or equivalent)
- FISCHER large slot screwdriver
- Current FISCHER retention/release adjustment table
- Approved mechanical testing device
- Screw extractor
- Tap extractor
- Hole plugs, plastic & wood
- FISCHER threaded plastic ski inserts
- Chisel
- Hammer

CREATING AN INFORMED CONSUMER

Customers, whether rental or retail, come to your shop with all levels of knowledge. The range extends from true experts who really know the sport and their equipment needs, to never-ever skiers who know they must rely totally on your expertise.

A key role played by a good shop, and a requirement in the US and Canada under the "FISCHER Retailer Indemnity Program", is providing information, guidance and instruction to all customers.

SPECIFICALLY THIS MEANS:

- Providing product and suitability information to help customers make an informed choice of which equipment models are right for them. The amount and type of advice given will naturally be different for each customer.
- The shop's responsibility is to be sure that each product sold or serviced is appropriate for the needs of its user.

- The shop must provide accurate information about the nature of the sport, and what equipment can and cannot do. Inform customers that there are risks inherent in the sport of skiing that no binding can protect against. It is imperative that each customer be informed there are limitations to the protection their equipment can afford and that injuries can and do occur in the normal course of skiing.
- Under no circumstances should you make any warranties or assertions about the customers safety on the hill. Speaking simply, no binding is “absolutely safe”. Well designed shop record forms address the disclosure and agreement subject very directly and professionally. Use them to your advantage by making sure customers read and understand the form before signing it. The following points must be explained to all customers (rental or retail) before they leave the shop with their equipment (consumer awareness checklist):
- Go through your workshop ticket and fully explain each task that has been performed by the shop.
- Explain how to use bindings and equipment. Let customers put on their boots and step in and out of the binding if need be.
- Remind skiers to clean their boots and bindings each time before stepping in. Tell them that they should always walk through clean snow before entering the bindings.
- Deliver the “Instructions For Use” booklet to retail customers. It is an important document and is essential for warranty service.
- Advise the customers to return to your shop periodically for maintenance and a system inspection. The service interval is once each 15–20 days of skiing, or annually, whichever comes first. Failure to adhere to this service interval will void the FISCHER Limited Warranty.
- Recommend care in transport: heels closed, bindings covered.
- Recommend care in storage: dry, moderate temperature, heels closed, boots not in bindings.
- Explain that bindings and boots must be kept clean for optimal function.
- Skiers should make a visual inspection of their system before each use, including the AFD pad which should be checked for wear, damage or loss. It is also wise to visually verify the release indicator value.

NOTE:

- The workshop ticket must be read, initialed and signed by the customer. If the customer is a minor, his or her signature should be obtained, along with that of the parent or guardian. If a parent or guardian is not available, the equipment should only be released if the proper signatures have been obtained.
- Remember, the customer’s signature is required in two places under the terms of the FISCHER Retailer Indemni-

ty Program. In order to avoid misunderstandings with the customer, please inform them of this requirement when equipment is taken in for service.

- If the customer is not the end user, every attempt should be made to make certain all aspects of the system are explained to the user, and to obtain his/her signature on the workshop ticket.

ABOUT TESTING

Testing is required for all FISCHER retail and rental systems as specified in this manual. Many consumers view system testing as a valuable service provided by professional shops. They expect their equipment will be properly tested, and are willing to pay for it. On the other hand, some customers may be reluctant to accept any additional costs. They may be especially resistant to charges made by the shop for testing and inspections of equipment which is being serviced. Following are some communication techniques that have been found to be helpful:

- Post your shop’s testing policy. A clear statement, prominently displayed, will reassure customers that they’re all receiving the same treatment. Consider a text similar to the following:

“Industry standards have defined shop testing procedures for your ski/boot/binding system. We’re proud to offer this service since it is in your best interest. While even the best ski equipment cannot eliminate all risks of injury, we strive to maximize your enjoyment of the sport by verifying the settings and function of your equipment. The extra time and expense of system testing will pay off for you in a better skiing experience.”
- Make your service shop a showplace. Place your testing bench in a prominent location. Many customers like to know what kind of work you’re doing for them. If you get a question, offer to let the skier watch.
- Proudly display diplomas and certificates received by your mechanics. Make their expertise known to your customers.
- Above all, don’t apologize for testing. It’s a valuable and necessary service well worth the cost.

ABOUT TESTING DEVICES

ASTM and ISO have defined specifications for ski equipment system testing devices. Only those devices that meet these recognized performance standards should be used to test systems that include FISCHER bindings. You should make it the responsibility of your testing device supplier to verify that their device fulfills all ASTM/ISO requirements. Each device has its own unique features and some will fit your shop’s needs better than others. Therefore, we can’t recommend a single device as universally “the best”. The following points, however, can be used as a guideline to getting the most out of your choice:

- Training is very important in the use of any device. Read the instructions thoroughly, and practice!
- To insure reproducibility from one technician to another a “Multiple Operator Reproducibility Test” should be performed by all users of the testing device. This simply requires that all technicians join in a “round robin” exercise where each tests the same system with the same test device. The goal is to verify that the testing techniques are the same and that all test results are comparable. Speak with your testing device supplier for the details on how to conduct this program.
- Beware of “black box” calculations that may be performed by some electronic testers, the calculations performed to arrive at an indicator value or determine an appropriate Torque Range could be based on old standards. Check the current FISCHER Adjustment Chart for applicable values.
- Periodic calibration of these devices is important, and this information should be documented in your shop records.
- Most important, never blindly trust the values given by any test device. This is just one tool to use in your evaluation of a complete release/retention system.

MAINTENANCE

Inform every customer of the simple fact that periodic maintenance is needed. If they don't bring their gear back for regular function checks, it is unreasonable to expect it to work as designed. Studies have shown that binding systems which have not been properly maintained have serious injury rates very much higher than those which have.

Following this simple, logical guideline is the single most effective way to decrease serious injuries dramatically. Have the system serviced by a FISCHER certified technician once each 15–20 days of skiing, or annually, whichever comes first.

FISCHER RETAILER INDEMNITY PROGRAM

Today's equipment may help reduce certain hazards involved in the sport, but the risk of injury remains.

The FISCHER Retailer Indemnity Program is designed to help formalize service procedures and minimize the risks to both you and your customer.

Under the plan, FISCHER will defend and indemnify the Authorized Retailer in bodily injury claims when certain conditions are met, including following all FISCHER required procedures.

The program benefits are not without limits, indemnification is not insurance, and it does not eliminate the need for a shop to have adequate insurance of its own. But, for the shop willing to make the investment in doing a quality job as an assembler of equipment systems from components, it is a key element in their Risk Management plan.

This is only a summary of the FISCHER Retailer Indemnity Program, complete requirements are listed in the current FISCHER Binding Indemnification Agreement. You should read this Agreement carefully.

Retailer benefits under the terms of the plan are based, in part, on the adequacy of the service work performed by the mechanic. For this reason, thorough employee training is essential. This manual and technical seminars are presented by FISCHER to help define appropriate shop procedures.

It is the responsibility of the FISCHER Authorized Retailer to see that all technical and product information materials provided by FISCHER Skis US LLC/Raymond Lanctot LTD, Can. are ordered and available in their shop.

This should be done with the aid of your FISCHER Representative while placing your FISCHER pre-season binding order.

THE FISCHER RETAILER INDEMNITY PROGRAM APPLIES ONLY TO THE FOLLOWING BINDINGS:

Race

RC4 Z 20 FF X Race Service (RD),
RC4 Z20 Freeflex Race Service
RC4 Z 18 FF X Race Service, RC4 Z 18 Race Service
RC4 Z 16 FF X Race Service, RC4 Z16 Race Service,
RC4 Z 17 Freeflex, RC4 Z 13 Freeflex
RC4 Z 11 Freeflex

C-Line

C-Line Z 13 RaceTrack, C-Line Z10 RaceTrack,
C-Line Z13 Flowflex 2.0, C-Line Z 9 Flowflex 2.0

High Performance

RC4 Z 17 Flowflex, RC4 Z13 Flowflex, Pro Z13 Flowflex,
RX Z13 Flowflex, RC4 Z 13 RaceTrack,
RC4 Z 13 Flowflex 2.0, RSX Z 13 RaceTrack,
RSX Z13 Flowflex 2.0, RSX Z12 Flowflex 2.0,
RC4 Z12 Flowflex 2.0, RC4 Z12 Powerrail,
RC4 Z12 Railflex 2, RC4 Z12 Flowflex,
FSX12 Flowflex, FX12 Flowflex
RSX 12 Powerrail, FSX12 Railflex 2, FX12 Railflex 2,

FX12, RC4 Z11 Powerrail, RC4 Z11 Railflex 2,
RS11 Powerrail, FS11 Railflex 2,
RS10 Powerrail, FS10 Railflex 2
RS9 SLR, RS9, RS10, FS10, RS11, FS11

Women

W 10 Womantrack, W 10 Powertrack
W 9 Womentrack, W 9 AC SLR, V 10 Powerrail
V9 MyStyle, V9 Railflex fw

Junior

RC4 Z9
FJ7 AC, FJ7 SLR, FJ7, FJ7 AC Junior Rail, FJ4 Junior Rail
FJ4 AC, FJ4 SLR, FJ4, FJ4 AC Junior Rail, FJ4 Junior Rail

Freeride/Slopestyle

Adrenalin 16 , Adrenalin 13
Attack 16, Attack 13, Attack 13 DEMO, Attack 11 DEMO
Attack 13 LT, Attack 13 AT, Attack 11
Ambition 12, Ambition 10
X17, X14, X13, X 11, X10, X9, X7

Rent

XTR 10 Pro, XTR 10 Rent, XTR 7 AC Pro, XTR 4 AC Rent
XTR 12 Pro, XTR 10 Pro Premount, XTR 13 Pro plus
XTR Pro 12 C-Line, XTR 12 Pro
XTR 4 AC Pro, XTR 9 Pro C-Line Premount
XTR 9 Pro, XTR 9 Pro Premount
FSX11 Railflex2 Demo, FX12 Railflex2 Demo

RETAILER AGREEMENTS AND INDEMNIFICATION AGREEMENTS

Both Agreements must be completed annually. This years Retailer and Indemnification Agreements should already be completed, if not please contact customer service or your sales rep. Completed Retailer Agreements, Indemnification Agreements and Employee Training Documentation Forms should be received at FISCHER Skis US LLC/Raymond Lanctot LTD, Can. no later than December 31, 2016.

SUMMARY OF REQUIREMENTS

These basic requirements help assure that the end product which is delivered to the customer is appropriate.

- Signed, current copies of the FISCHER Authorized Retailer Agreement and the FISCHER Bindings Indemnification Agreement must be on file with FISCHER Skis US LLC/Raymond Lanctot LTD, Can.
- The shop must adhere to 16I17 FISCHER procedures for selection, mounting, adjusting, testing and/or servicing of system components as detailed in this manual.
- The actual FISCHER retention/release adjustment, or its equivalent, must be used.
- A FISCHER Certified Mechanic must properly mount, inspect, adjust and/or service system components and/or check to make sure all service, adjustments, testing and record keeping were properly completed.

- Mechanics must receive full training, including hands-on practice in the use of system testing devices, as provided by the testing device supplier. A multiple operator reproducibility test should be completed and results documented by the shop each season.
- The shop must maintain records of all retail/rental testing and/or service work for 5 years or for the length of the statute of limitations in the state where your business resides, whichever is longer. Bear in mind that the statute of limitations for minors begins only when they come of legal age.

PAPERWORK REQUIREMENTS

FISCHER Retail/Rental Workshop tickets have proven their importance in the legal system, and we strongly recommend their use (see elsewhere in this manual). At the very minimum, records must contain the following information:

- Identification of shop and customer: name, address, phone.
- Date of transaction or work.
- Information on which binding settings are based: skier height, weight, skier type, age, boot sole length.
- A full description of the equipment being serviced or rented (skis/boots/bindings), including but not limited to brand, model, size and serial numbers.
- Skier code, "Initial" binding release/retention settings, and final settings.
- Signed, dated statement from the FISCHER Certified Mechanic that all manufacturer's procedures have been completed, and the signature of the mechanic who performed the service (if they are different individuals).
- An agreement dated and signed by the customer, the language of which is substantially similar to the current FISCHER form. This agreement must include the following points:
 - User verification of skier information.
 - WARNING that there are risks of injury inherent in the sport of skiing and that the customer accepts those risks.
 - DISCLOSURE of the equipment's limitations, that it will not release, retain or prevent injury under all circumstances, and is no guarantee of the user's safety.
 - RELEASE language whereby the user releases the retailer, manufacturer and distributor from liability and damages, to the fullest extent allowed by law.
 - STATEMENT that no warranties of any kind are offered by the shop beyond those offered by FISCHER.
 - AGREEMENT that instruction in the use of the equipment has been received, that the skier height, weight, skier type, age, boot sole length, as well as the settings on the binding match those on the record form, and that the skier will inspect the system, including the binding's AFD, before each use.
- Signatures by both the customer and FISCHER Certi-

fied Mechanic are required by for the FISCHER Retailer Indemnity Program.

NOTE:

- Any changes in documentation requirements must be authorized in writing by FISCHER Skis US LLC/Raymond Lanctot LTD, Can. POST ACCIDENT REPORT (SEE SAMPLE IN APPENDIX). In addition to the above information on the system's performance, fill out a Post Accident Report when you become aware that an injury has occurred. Keep this document for 5 years or the duration of the statute of limitations for minors, whichever is longer.

IN THE EVENT OF AN INJURY CLAIM

- Notification to FISCHER Skis US LLC/Raymond Lanctot LTD, Can. by retailer, of any bodily injury claim, must be made in writing on or before the tenth calendar day from the date on which the retailer first received notice of any such claim. In the event of a lawsuit the retailer must notify his/her own attorney and must cooperate with FISCHER Skis US LLC/Raymond Lanctot LTD, Can. and respond to requests as required.
- In a rental situation, from the time that any injury claim is made to the retailer, the retailer must maintain possession of any equipment that may have been involved in the accident. (Equipment may be returned to service upon passing a post-accident investigation.)
- In the event of an injury, a Post Accident Report must be completed and retained if the shop is in possession of all components of the system. If the entire system is not available for test it should be noted and all pertinent information such as equipment condition, visual indicator settings, and any equipment abnormalities should be recorded.

NOTE:

FISCHER reserves the right to deny indemnity if FISCHER requirements are not fulfilled. Strict compliance by the dealer with all requirements, as stated in the FISCHER Binding Indemnification Agreement, is a condition precedent to favorable consideration of a request for indemnity. This is only a summary. The precise requirements of the FISCHER Binding Indemnification Program are contained in your FISCHER Binding Indemnification Agreement.

FISCHER RETAILER LIMITED WARRANTY

FISCHER's authorized distributor in the country in which this product was first sold at retail, warrants to the first retail purchaser or user that this product shall be free from defects in materials and workmanship. This limited warranty, as well as any implied warranty, shall expire two years from date of the initial retail purchase. In USA and Canada this period for retail bindings is four years from date of purchase or five years from date of manufacture, whichever period expires earlier. For rental bindings it is always two years from date of purchase.

For warranty claims or service, the product must be returned at the consumer's expense to the place of purchase, or to another authorized FISCHER dealer or to the authorized FISCHER distributor in the country of purchase.

The "Instructions for Use" booklet, the proof of purchase, and proof of periodic service must accompany all bindings returned under warranty.

LIMITATION OF LIABILITY

Cosmetic damage that does not affect function, and any damage caused by abuse or improper use, are not covered.

Parts subject to normal wear and tear, such as AFD's, brakes, windows, plastic or metal tracks, are not covered. Your sole remedy under the Limited Warranty or any implied warranty shall be limited to the repair or replacement, at FISCHER's and its distributor's sole option, of the subject product or parts thereof. In no event shall FISCHER or its agents be liable for incidental or consequential damages or for any cost of transporting or shipping the product, whether the claim is based upon contract, warranty, negligence or product liability, including, without limitation, loss to property other than the bindings, loss of use of any property, or other economic losses. Neither FISCHER nor any distributor or dealer shall be liable for contribution or indemnification, whatever the cause. This warranty may not be assigned or transferred. FISCHER's obligations under any warranty shall be limited, to the greatest extent allowed by law, as provided in this Limited Warranty. Some states do not allow limitations on implied warranties or on certain damages or remedies, so some or all of these limitations may not apply to you. This Limited Warranty gives you specific legal rights, and you may also have other rights which vary in different states, provinces and countries.

SERVICE UNDER THE FISCHER WARRANTY

Products requiring service under the terms of the warranty should be dealt with as follows:

- Send the complete binding set to the authorized distributor where evaluation will be made and warranty action taken if required.

- If a clear warranty situation exists, and the shop wishes to replace the pair of bindings products out of stock for a customer, the shop may do so after the approval of the ski warranty department of your FISCHER distributor. Be sure to check suitability and mounting hole pattern before making a change of model.

- When possible, the replacement should be of the same model as the returned product.

- If the same model is not available, the shop should contact the authorized FISCHER distributor warranty department for authorization before a more expensive model is selected for replacement.

- If a replacement is made from retailer stock, the complete binding set should be returned to the authorized FISCHER distributor as soon as possible. The packing list must clearly state which model was used for replacement.

- The "Instructions for Use" booklet (warranty), and proof of purchase must accompany all products returned for consideration.

- No credits will be issued.

- The authorized FISCHER distributor reserves the right to deny replacement to the retailer if the alleged problem is not verified or if products are returned without the "Instructions for Use" booklet and proof of purchase.

- Replacement bindings are covered by the warranty stated above.

- Any bindings returned to the authorized FISCHER distributor due to inappropriate release values (i.e. values which fall outside the "In-Use" tolerance range on the current FISCHER Adjustment Chart) must be accompanied by a completed System Performance Report. The report form is printed in this manual; no warranty action will be taken on release value related claims unless this report accompanies the returned bindings.

Distributor addresses:

FISCHER Skis US LLC	FISCHER Canada Raymond Lanctot LTD.
60 Dartmouth Drive, Auburn, NH 03032 USA	5290 boulevard Thimens Saint-Laurent, QC, CANADA H4R 2B2
Phone: 603-314-7110	Phone: 800-361-5045

RISK MANAGEMENT

INDEMNIFICATION

Indemnification simply means that someone agrees to reimburse you for certain costs. In the ski industry it normally means that provided you fully follow the manufacturer's requirements and install and adjust the binding system correctly, the manufacturer or distributor will provide a defense and pay any judgment which may be entered against you if you are the subject of a claim or suit by a customer who claims to have suffered bodily injury as a result of using certain equipment.

The key here is you must be able to prove that you did your job properly in order to qualify. If you do not, you will not be entitled to a defense or indemnification in the event of a claim.

YOUR PERSONAL LIABILITY

It's simple: If you make a mistake which causes harm to another, you can be held liable for it. Be very careful not to make verbal warranties that extend beyond those made by FISCHER. Read the manufacturer's literature and warranties carefully. If a feature or benefit is not mentioned there, don't mention it to the customer.

SHOP LIABILITY INSURANCE

No indemnification program is a substitute for liability insurance. Common sense dictates that you should have an insurance policy that covers your shop and employees for commercial general liability and completed operations. Check with your insurance broker.

SHOP PROCEDURES TO REDUCE LEGAL EXPOSURE

Risk Management has become a very important area in virtually every industry. In today's world it is more important than ever to do as much as possible to recognize how and where we might be exposing ourselves to a potentially serious problem. FISCHER has been the leader in molding valuable risk management concepts into a program that virtually the entire ski industry follows today. FISCHER has defined proper shop practices and how shop personnel and customers need to interact in order to maximize skiing enjoyment while lowering the risks of liability. If these procedures are followed properly, both the skier and the industry are well served. In the event of a mishap, the programs documentation and record keeping system will provide strong evidence of work performed.

YOUR OBLIGATIONS UNDER THE FISCHER RETAILER INDEMNITY PROGRAM

Selecting equipment for your customer.

- Make sure the products are suitable for the skiers height, weight, ability, shoe size and level of ability.
- Always make sure your recommendations are consistent with the manufacturer's.

BINDING SELECTION

Generally, the idea that top of the line products offer the greatest margins for safety as well as performance and durability is correct - provided the skier fits the weight range of the product. Combine this knowledge with our weight and ability recommendations for the skier when selecting a binding. Avoid selling a product with the idea that the customer will grow into it. If a product is not suitable for their current requirements make another choice. Avoid the temptation to do the customer a favor by re-writing the rules. More often than not, all you will do is cause problems. At the time of delivery to the customer, the bindings must be accompanied by all the informational materials supplied by the manufacturer, i.e., pamphlets, forms, etc.

The product must be fully demonstrated to either the intended user or their parent or legal guardian if the child is a minor. This includes instructions on inspecting the low friction surfaces, cleaning the boot sole, entry of the binding, re-entry after releasing on the hill and exiting the system.

You must also explain what care and maintenance the skier is responsible for, as well as when to return the equipment to your shop for a thorough function check. Routine maintenance it is the most cost effective thing a skier can do to protect their well being.

BOOT SELECTION

Make sure the customer's boot choice is consistent with their level of skiing and that the boots meet all current DIN or ISO standards.

SKI SELECTION

Take care to ensure that the skier's intended use of the chosen equipment is consistent with the manufacturer's recommendation for the skier's weight and level of skiing. This is another area where regular maintenance is critical. It is only logical that skis which help keep your customer upright reduce their overall chance of injury.

RACING BINDINGS

Certain binding models are produced by FISCHER each year for the exclusive use of qualified competitors under the supervision of FISCHER Technical Specialists. These bindings are not covered by either the FISCHER Warranty or any Dealer Indemnity Program. We recommend you decline to service them, and warn against their use. In a similar vein some skiers may wish to use retention settings which are excessive. DIN settings over 10 do not satisfy current industry standards and should not be used. Adjustments exceeding this range are made on one's own risk.

COMPLETING THE WORK ORDER WITH THE CUSTOMER

It is critical that certain basic information be included on all shop work orders. While we do not require it, the easiest way to make sure the form you use fits FISCHER's requirements is to use ours.

Once the customer has selected equipment or described the repair or service to be performed, the technician must ask the customer to complete a portion of the Work Order Form which includes their Name, Address, Phone number, Weight, Height, Age, Sex, and Skiing ability. There are few things more embarrassing than having a customer come in to pick up a pair of skis that could not be serviced due to an improperly filled out form, or an unforeseen technical problem.

The best way to avoid this is to have a FISCHER Certified Technician thoroughly inspect all incoming work, and check the paperwork. The skier must then sign indicating that they have read, understood, and agreed to the terms of your Rental/Repair agreement (this agreement must comply with FISCHER Dealer Indemnity Program requirements). It is also important that the customer be informed that they will be expected to verify in writing that the indicator settings agree with what is written on the form, and that they have been instructed in the use and maintenance of their equipment, and fully understand it. This procedure must be completed before the transaction is consummated. Remember, the customer has the option of going to another store if the terms of the contract are not acceptable to them, and under no circumstances should the transaction go any further without their signature. The end user, or their agent, must sign the incoming work order.

SHOP PROCEDURES SUMMARY

For in depth details, see the "Binding Installation" section of this manual.

- Follow FISCHER procedures for inspection, mounting, adjustment and maintenance as appropriate.
- Confirm that toe and heel indicator values match those specified on the actual FISCHER Adjustment Chart.
- Using a calibrated testing device, according to the manufacturer's instructions for use, "exercise" the binding by releasing it at least once in each direction (clockwise and counter-clockwise at the toe, vertically at the heel). Then measures Twist and Forward Lean Torque Values. The middle quantitative value of 3 releases in each direction should be used as the test result.
- Compare Twist and Forward Lean test, results with the System Inspection Ranges on the actual FISCHER Adjustment Chart.
- After the equipment is adjusted to the skier's needs according to the manufacturer's standards, the certified technician signs the form indicating that the work has been completed according to the manufacturer's specifications.
- With testing complete, the FISCHER Certified Technician must complete and sign the workshop ticket. Be sure the Final Indicator Settings are correctly shown there. The workshop ticket should simply reflect that the system has "passed all tests" or that "all manufacturer's procedures have been completed".

PROCEDURES FOR RETAIL CUSTOMER PICK-UP

When the Retail Customer or his representative comes in to pickup the equipment, the store employee has a fantastic opportunity to improve the skier's safety and enjoyment, while minimizing the risk of a law suit later on. All that's involved is properly informing the skier about the realities of skiing and ski equipment.

- Explain the function and operation of the binding, including a review of the manufacturer's pamphlet.
- Explain the settings that show in the release setting windows and how they were derived by referring to the manufacturer's release adjustment charts.
- Explain how much proper maintenance of the entire system (boots, bindings and skis) can improve their enjoyment and margins for safety. Also make it clear that skiing, like any sport, has its risks, and equipment can not eliminate them.
- Have the customer sign the form again indicating that they have been instructed on the use of the equipment and that they verified that the visual release indicators on the bindings correspond to the manufacturer's recommended settings shown on the work order ticket.

ARCHIVING RECORD

Should you become one of the few that must defend against a law suit you will soon find out that the very best defense is made of paper. For this reason we recommend that you start out each ski season with a huge, brand new, manila envelope. Over the course of the season you should fill it with the following items:

- Collect a copy of the technical manual for each and every binding, boot and ski on the market. Be especially diligent with those you carry or work on regularly.
- Copies of the manufacturer's customer instruction booklets.
- Technician employment applications. Make sure they have the address of someone who will always know where they can be found, and is likely to stay put – Moms are good. This can be invaluable if you need the technician as a witness.
- A listing of all technician certifications and their dates. Keep all certification records as well.
- Copies of any pertinent wall charts, customer information posters etc.
- A copy of your shop procedures, including training materials, rental and repair shop practices, and binding setting charts.
- Copies of rental fleet test data.

This type of supporting documentation can be tremendously useful for your lawyer.

STORAGE OF FORMS

All forms containing the customer's signature must be kept for a minimum of five years or the term of the statute of limitations in the state where the injury occurs, or your state, whichever is longer. As a practical matter you have no idea where or when your customer may sustain an injury on this equipment.

Naturally, should an injury occur to either an adult or a child, keep the original form in a safe place until the case is completely resolved.

Risk Management is really just common sense. Do your job well, have integrity, keep your customers well informed, and keep proper records. Follow these simple rules and you will have very few problems.

16117 CERTIFICATION EXAM



1. Freeflex bindings:

- A - Maintain consistent forward pressure and release/retention value during ski flex.
- B - Reduce ski vibrations for improved edge grip and control.
- C - Have a total stand-height of 21 mm to leave room under FIS regulations for race plates.
- D - Provide all of the above.

2. The FISCHER roller-pincer system includes:

- A - 4 rollers and glide elements that minimize friction.
- B - 180° release range with programmed elasticity to reduce peak loads on the knee.
- C - Direct power transfer to the edge.
- D - All of the above.

3. FJ 7 AC, XTR 7 AC Pro bindings can accept:

- A - Adult soles only on the FJ 7 AC.
- B - Child soles only on the FJ 7 AC.
- C - Adult and child soles on all models.
- D - Adult and child soles on the rental bindings only.

4. When adjusting the 92 template for Freeflex models:

- A - Lock the lever in the far right position after measuring the boot.
- B - Use the number on the template that matches the sole length.
- C - Adjust the template to the boot, put the lever in the middle position and set to the nearest centimeter mark until the template locks in position.
- D - Use setting 23 for all adult boots.

5. To activate the Freeflex dampening function:

- A - Turn the eccentric screw in the middle of the band until the marks are aligned.
- B - Do not use a power screwdriver.
- C - Always deactivate when dismantling the binding.
- D - All of the above.

6. FJ 4 AC, XTR 4 AC Rent, XTR 4 AC Pro:

- A - Use a 94 W drill template for mounting.
- B - Provide consistent performance for adult and child soles.
- C - Have a toe height adjusted by sliding an adjustment wedge under the toe.
- D - All of the above.

7. The FISCHER XTR 10 Pro Rental binding:

- A - Offers a boot sole range of 263 - 391 mm.
- B - Utilizes a single letter code for quick adjustments of both heel and toe.
- C - Uses a tool-free, one-touch mechanism.
- D - All of the above.

8. The FISCHER Rental Boot Indicator (SymRent Caliper) can be used to:

- A - Measure boot sole length in millimeters and choose a Single Code.
- B - Check for excessive wear on the boot sole dimensions.
- C - Determine whether the boot sole is adult or child.
- D - All of the above.

9. For all FISCHER bindings, the release/retention settings:

- A - Must be verified with an approved calibrated testing device per industry standards.
- B - Must begin with the FISCHER Adjustment Chart for initial indicator settings and torque values.
- C - Must be clearly recorded on the workshop ticket.
- D - All of the above.

10. What is the correct procedure for adjusting forward pressure on Fischer Freeflex Pro or two-piece bindings:

- A - Lift the tooth lock, remove the boot, reposition the binding, then close the lock.
- B - Remove the boot, lift the tooth lock, and reposition the binding, then close the lock.
- C - Always turn the forward pressure adjustment screw with the boot in the binding.
- D - Never turn the forward pressure adjustment screw with the boot in the binding.

11. The FISCHER ABS system:

- A - Cleans itself as it rotates.
- B - Enables the boot to exit the binding virtually friction free.
- C - A and B.
- D - Aligns the forward pressure of the binding.

16I17 CERTIFICATION EXAM

12. Forward Pressure on the RS 10 are measured:

- A - When the boot is not in the binding.
- B - With the boot in the binding, the pointer on the lower part of the heel should be in front of the scribed area.
- C - With the boot in the binding, the pointer should rest in the middle of the scribed area on the toothed lock.
- D - None of the above.

13. FISCHER binding warranty covers defects in materials and workmanship:

- A - For a period of 4 years from the date of purchase.
- B - For a period of 5 years from the date of manufacture.
- C - Both A and B.
- D - For a period from when the customer's money is taken and they reach the front door.

14. If a diagonal heel housing wobbles in the heel track you should:

- A - Follow the simple procedure for replacing the worn out heel glide insert.
- B - Ignore the situation.
- C - Send the bindings to FISCHER warranty for replacement.
- D - Smack the heel piece gently but firmly against the hood of your car.

15. To complete your FISCHER certification:

- A - Review the FISCHER Technical Manual.
- B - Practice the procedures with hands on in-store training.
- C - Send in your completed Employee Certification Answer Sheet.
- D - All of the above.

16. Check for proper ski brake stopping power:

- A - Check that the brake extends 130mm below the ski.
- B - Check that the brake can lift the ski and boot.
- C - Make sure the components comply with the brake matrix and the binding-brake-compatibility chart and chart in the manual.
- D - All of the above.

17. What is the correct color-letter code of brakes for AAAmbition bindings:

- A - Red
- B - Yellow
- C - Green
- D - All of the above.

Please refer to the 16I17 FISCHER Release/Retention Adjustment Table for the next four questions:

18. A type 2 male skier weighing 165 pounds that is 5'10" tall and 36 years old with a boot sole of 310 mm has a skier code of:

- A - L.
- B - K.
- C - J.
- D - 5.

19. The DIN and Inspection Range for twist for this skier is:

- A - 6.50 and 43-78.
- B - 5.50 and 43-58.
- C - 6.50 and 50-67.
- D - 5.50 and 37-67.

20. A type 3 skier weighing 190 lbs that is 6'1", and 35 years old with a boot sole length of 321 mm will have a DIN of:

- A - 7.0
- B - 8.5
- C - 8.0
- D - 10.0

Refer to the pages listed in the Technical Manual for more information.

Copies may be made for additional employees.

Only fax in Answer Sheet.

EMPLOYEE CERTIFICATION ANSWER



PLEASE READ CAREFULLY

- Duplicate copies of this form only will be accepted.
- Sections 1 - 4 must be completed in full before this form can be processed. Unanswered or incomplete information may result in failure of exam. Technicians with failed exam forms will be contacted by FISCHER Skis US LLC or Raymond Lanctot LTD., Can.
- Incorrect information in sections 1 - 4 may result in denial of dealer indemnification.
- A score of at least 80% (16 correct answers) must be achieved in Section 4 to pass this exam.
- FAX # FISCHER Sports USA: 603-314-7124; Raymond Lanctot LTD., Canada: (514) 342 4059

1. TECHNICIAN INFORMATION

Today's Test Date	
Dealer (Customer) Number	
Technician Name (please print)	
Technician Signature	Initials
Technician's City, State, Zip	E-Mail

2. DEALER MAILING ADDRESS

Dealer Name	Street/P.O. Box
City	State/Province Zip/Postal Code Country

3. SHOP ADDRESS

Shop Name	Street/P.O. Box
City	State/Province Zip/Postal Code Country
Telephone	Website/E-Mail

4. EXAM ANSWER SECTION

Indicate one correct answer for each question given.

- | | | | | |
|--|--|---|---|---|
| 1. <input type="checkbox"/> a <input type="checkbox"/> b <input type="checkbox"/> c <input type="checkbox"/> d | 5. <input type="checkbox"/> a <input type="checkbox"/> b <input type="checkbox"/> c <input type="checkbox"/> d | 9. <input type="checkbox"/> a <input type="checkbox"/> b <input type="checkbox"/> c <input type="checkbox"/> d | 13. <input type="checkbox"/> a <input type="checkbox"/> b <input type="checkbox"/> c <input type="checkbox"/> d | 17. <input type="checkbox"/> a <input type="checkbox"/> b <input type="checkbox"/> c <input type="checkbox"/> d |
| 2. <input type="checkbox"/> a <input type="checkbox"/> b <input type="checkbox"/> c <input type="checkbox"/> d | 6. <input type="checkbox"/> a <input type="checkbox"/> b <input type="checkbox"/> c <input type="checkbox"/> d | 10. <input type="checkbox"/> a <input type="checkbox"/> b <input type="checkbox"/> c <input type="checkbox"/> d | 14. <input type="checkbox"/> a <input type="checkbox"/> b <input type="checkbox"/> c <input type="checkbox"/> d | 18. <input type="checkbox"/> a <input type="checkbox"/> b <input type="checkbox"/> c <input type="checkbox"/> d |
| 3. <input type="checkbox"/> a <input type="checkbox"/> b <input type="checkbox"/> c <input type="checkbox"/> d | 7. <input type="checkbox"/> a <input type="checkbox"/> b <input type="checkbox"/> c <input type="checkbox"/> d | 11. <input type="checkbox"/> a <input type="checkbox"/> b <input type="checkbox"/> c <input type="checkbox"/> d | 15. <input type="checkbox"/> a <input type="checkbox"/> b <input type="checkbox"/> c <input type="checkbox"/> d | 19. <input type="checkbox"/> a <input type="checkbox"/> b <input type="checkbox"/> c <input type="checkbox"/> d |
| 4. <input type="checkbox"/> a <input type="checkbox"/> b <input type="checkbox"/> c <input type="checkbox"/> d | 8. <input type="checkbox"/> a <input type="checkbox"/> b <input type="checkbox"/> c <input type="checkbox"/> d | 12. <input type="checkbox"/> a <input type="checkbox"/> b <input type="checkbox"/> c <input type="checkbox"/> d | 16. <input type="checkbox"/> a <input type="checkbox"/> b <input type="checkbox"/> c <input type="checkbox"/> d | 20. <input type="checkbox"/> a <input type="checkbox"/> b <input type="checkbox"/> c <input type="checkbox"/> d |

FISCHER OFFICE USE ONLY

Pass	Fail
Certificate Number	Date Entered Initials

USE OF NON-RECOMMENDED SETTINGS

SKIERS REQUESTING SETTINGS NOT RECOMMENDED BY FISCHER

The 16I17 FISCHER Release/Retention Adjustment Table is the only adjustment chart recommended for use by FISCHER dealers during the 16I17 season.

Some skiers may request settings different from those in the FISCHER Release/Retention Adjustment Table. Most of these concerns can be addressed by following the procedures for reclassifying skier type and for troubleshooting which follow the instructions for using the FISCHER Release/Retention Adjustment Table.

FISCHER and the ISO/ASTM standards organizations do not recommend the use of release/retention settings outside of these tolerances, but skiers occasionally may request such settings. FISCHER recognizes a skier's right to choose other settings, but if the skier requests settings outside of those derived from the normal procedures for re-classifying skier type and for trouble - shooting, the shop may either:

1. Adjust the system to the setting derived from FISCHER Release/Retention Adjustment Table and instruct the skier on how to change the setting (if this done, make a note to this effect on the workshop or rental form), or
2. Adjust the system to the skier's individual request, but only if the technician notes on the workshop or rental form the reason the higher or lower setting was requested. Do not in any case adjust the system to a release/retention value higher than the maximum acceptable setting at the bottom of the FISCHER Release/Retention Adjustment Table. The customer must verify the request for the higher or lower settings by signing and dating the workshop or rental form by the reason noted next to the setting request. The skier must also read and sign a warning, release and indemnity agreement identical to the one printed on this page. In such cases, the system will only be indemnified if all other conditions of indemnification are met and the signed warning, release and indemnity agreement are attached to the completed workshop or rental form.

WARNING, RELEASE AND INDEMNITY AGREEMENT

I, _____, hereby acknowledge that I have been advised by the _____ (rental shop, sales department, etc.) that settings which I have requested for my bindings (Model _____) is not the setting recommended by the manufacturer of the bindings for a skier of my height, weight, age and skier type. I understand and acknowledge that there may be an increased risk of injury or death to me as a result of my own personal preference for these binding settings.

To the fullest extent allowed by law, I hereby waive and release all claims arising from the use of the bindings and release from all liability the shop, the distributor and the manufacturer, their agents and employees, and I further agree to indemnify them from any and all liability or harm or damage of any kind whatever which may result from the use of these bindings by myself or anyone I allow to use the bindings.

I, the undersigned, have read and understand this liability release agreement, and agree that it is binding upon me, my heirs, guardians, administrators, assigns, and legal representatives. If any part of this agreement is held to be invalid or unenforceable, the remainder shall be given full force and effect.

 Skier's Signature
 (or that of the skier's parent or guardian)

 Shop Manager's Signature

POST ACCIDENT INSPECTION REPORT



Date of Accident	Workshop Ticket #
Skier Name	Skier Phone
Address	Witness Name
City, State, Zip	Witness Phone

SKIER'S DESCRIPTION OF ACCIDENT AND INJURY

(Use Back For Additional Comments)

DESCRIPTION OF SYSTEM

		RENTED	PURCHASED
Ski Brand	Model	Size	
	Serial #	Inv. #	
Boot Brand	Model	Size	
Binding Brand	Model	Size	

CONDITION OF SYSTEM

Are the boot soles within industry standards?	Yes	No	
Are all buckles, boot adjustments functioning correctly?	Yes	No	
Are the A.F.D.'s intact?	Yes	No	
What are the Visual Indicator Settings?	Toe	Heel	
Is the Forward Pressure set correctly?	Yes	No	
Is the Toe Height set correctly?	Yes	No	NA
Do the brakes function smoothly?	Yes	No	
Is the ski bent delaminated or damaged?	Yes	No	
Describe:			
Was the equipment returned to service post-accident?	Yes	No	

MECHANICAL SYSTEM TESTING

Testing Device	Last Calibration date	/	/
	Clockwise	Ctr. Clockwise	Clockwise
	Toe L		R
	Heel L	R	

BACKGROUND

Shop Name	
Inspected By	Inspector Signature
Checked By	Checker Signature



© 2016

W40716_ENGL
ALPINE TECHNICAL MANUAL



9 002972 1196089

fischersports.com